



CIMON Panel-PC

- Display-Size 12,1", 15" and 19"
- Compact - fan-less cooling system - Windows XP® embedded



Features

Model	12,1"		15"			19"
	CM-P12DS	CM-P12DH	CM-P15DS	CM-P15DH	CM-P15DP	CM-P19DP
Display Type	TFT Color LCD (15P DSUB VGA Connector)					
Colors	16 Million					
Resolution	XGA (1024 x 768) (8-Wire Resistive)					
RAM	DDR2-SDRAM 1GB / PC2-5300 (2GB max.)					
Storage	CF 4GB	HDD 80GB	CF 4GB	HDD 80GB	HDD 80GB	HDD 80GB
Optional: Storage expansion	16GB/32GB/SSD		16GB/32GB/SSD		32GB/SSD	
CPU	ULV Intel® Celeron® M 600MHz					
Graphic Chip	Intel® GMA 900 integrated Intel® 915GME					
Interface	Serial	RS-232/RS-422/RS-485 1 Port / RS-232C 3 Ports				
	Ethernet	GIGABIT Ethernet, 2 Ports				
	Parallel	1 Port				
	PS/2	Keyboard and Mouse				
	USB	USB 2.0, 4 Ports				
	Audio	1 Port				
CD-ROM	no				yes	
PCI Slot	no				1 slot	
Operating System	Windows® XP (Embedded)					
Utility Program	EWF (OS Protection)/AMI-Rescue (BIOS Initialization)					
Power Requirements	90~240V AC					

Dimensions W x H x D [mm]

	P12DS/ P12DH	P15DS/ P15DH	P15DP (PCI)	P19DP (PCI)
B1	318	381	381	462
B2	330	395	395	480
B3	319	382	382	463
H1	238	296	296	371
H2	250	310	310	390
H3	239	297	297	372
T1	82	89	89	113
T2	-	143	143	-

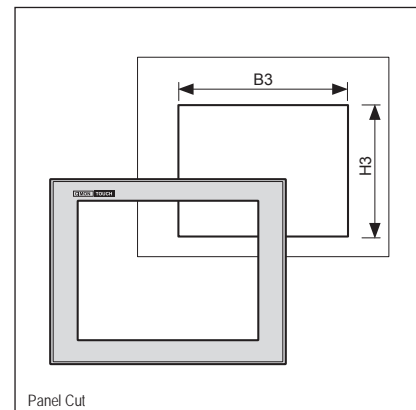
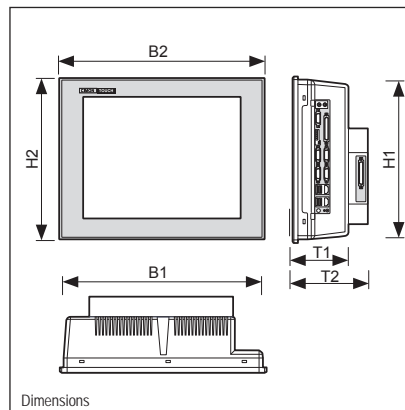

Hardware-Specification

1	Mouse & Keyboard
2	Printer
3	COM 1/COM 2/COM 3/COM 4 (RS-232C)
4	LAN 1/LAN 2
5	USB (Type A-B)
6	Audio
7	VGA
8	COM 1 RS-422/RS-485

