

**TOSHIBA**

Integrated Controller  
Model 2000 **V**series

**Sequence Controller**

**S2E**

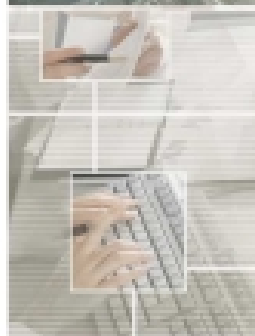

## S2E System Components

### S2E CPU Module

Type	Description
PU612E	Program memory: 32Ksteps I/O points: 2048 points

### Power Supply Module

Type	Description
PS693	100 to 240Vac input
PS632	24Vdc input
PS652	100 to 110Vdc input

### Base (main/expansion units common)

Type	Description
BU668	8 I/Os at both main and expansion units
BU666	5 I/Os at main / 6 I/Os at expansion
BU664	3 I/Os at main / 4 I/Os at expansion

### Expansion I/O Interface

Type	Description
IF661	For main and expansion units common

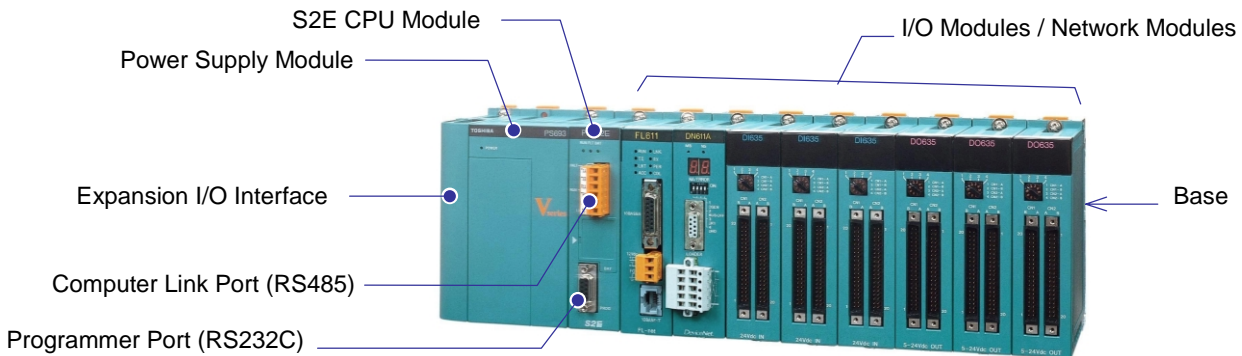

### Digital Input Module

Type	Description
DI632D	8 points (isolated), 12 to 24Vdc/ac input
DI633	16 points, 12 to 24Vdc/ac input
DI634	32 points, 24Vdc input
DI635	64 points, 24Vdc input
DI635H	64 points, 24Vdc input (high-speed)
DI653	16 points, 100 to 110Vdc input
IN653	16 points, 100 to 120Vac input
IN663	16 points, 200 to 240Vac input

### Analog Input Module

Type	Description
AD624L	4 channel, 1-5V/4-20mA, 8-bit
AD634L	4 channel, 0-10V, 8-bit
AD624	4 channel, 1-5V/4-20mA, 12-bit
AD674	4 channel, $\pm 10V$ , 12-bit
AD668	8 channel, $\pm 10V/1-5V/4-20mA$ , 16-bit
AD628S	8 channel (isolated), 0-5V/0-20mA, 12-bit
AD638S	8 channel (isolated), $\pm 10V$ , 12-bit
RT614	4 channel, Pt100 input, 12-bit
TC618	8 channel, TC (K/J/E) input, 16-bit

### Digital Output Module

Type	Description
DO633	16 points, 24Vdc output
DO633P	16 points, 24Vdc output (current source)
DO634	32 points, 24Vdc output
DO635	64 points, 24Vdc output
AC663	12 points, 100 to 240Vac output
RO663	16 points, relay output, max. 240Vac/24Vdc
RO662S	8 points (isolated), relay, max. 240Vac/24Vdc

### Analog Output Module

Type	Description
DA622L	2 channel, 1-5V/4-20mA, 8-bit
DA622	2 channel, 1-5V/4-20mA, 12-bit
DA672	2 channel, $\pm 10V$ , 12-bit
DA664	4 channel, $\pm 10V/1-5V/4-20mA$ , 16-bit
DA624S	4 channel (isolated), 0-20mA, 16-bit, hold

### Network Module

Type	Description
FL612	FL-net controller station (Ver. 2.0)
SN621	TOSLINE-S20, co-axial cable type
SN622	TOSLINE-S20, optical cable type (bus)
DN611A	DeviceNet scanner module
UN611	TOSLINE-F10 master station
UN612	TOSLINE-F10 remote station

### Special I/O Module

Type	Description
PI632	2 channel pulse input, 100kpps, 5/12/24Vdc
PI672	2 channel pulse input, 100kpps, RS422
CD633	16 points, change detect, 12 to 24Vdc input
MC612	2 axis positioning, pulse output, 200kpps
MC614	4 axis positioning, pulse output, 1.3Mpps
CF611	Communication interface, RS232C, 1 port

### Misc

Type	Description
SP600	Empty slot dummy module
BT611	Spare lithium battery

### I/O Expansion Cable

Type	Description
CS6R3	0.3 m length
CS6R5	0.5 m length
CS6R7	0.7 m length
CS6*1	1.2 m length

## System Configuration

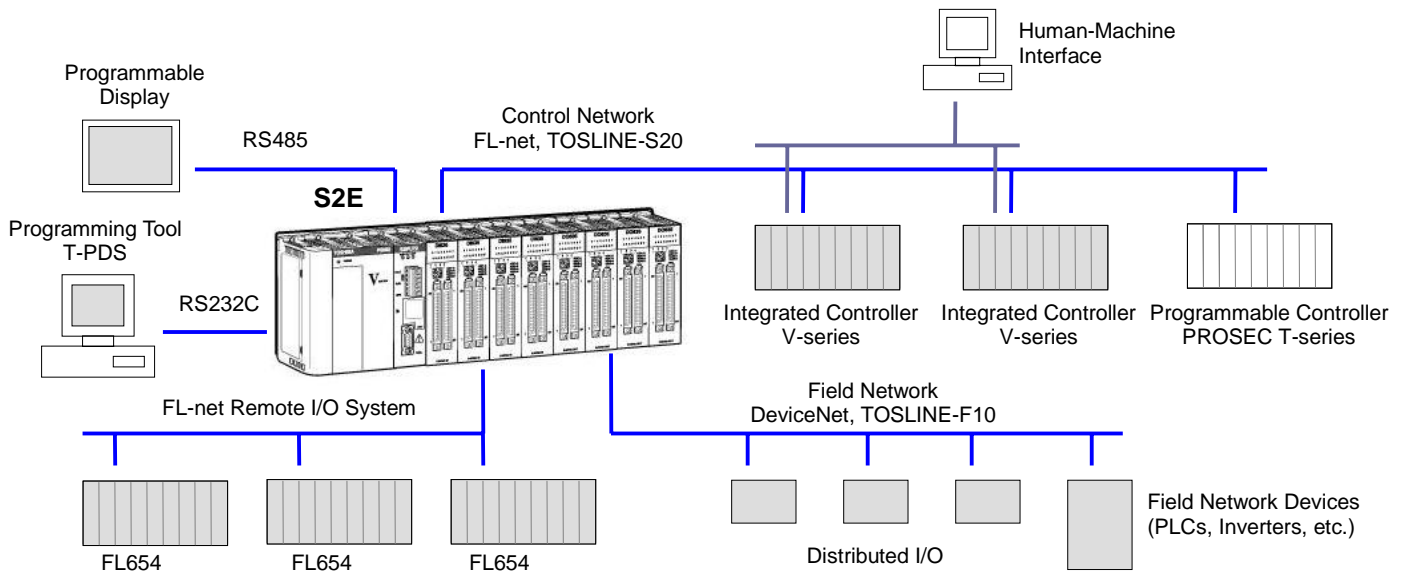

### Control Network

The S2E supports Ethernet based open network FL-net and Toshiba's high-speed network TOSLINE-S20. Flexible network configuration is available.

**FL-net:** Open standard Controller level network that is standardized in JIS (Japan Industrial Standard). The FL-net is the Ethernet based multi-vender network, which enables high-speed data linkage with PLCs, robot controllers, numerical controllers, displays, etc.

**TOSLINE-S20:** Toshiba's control data network using co-axial or optical cable. The transmission speed is 2Mbps. Because of its high efficiency protocol, high throughput is achieved. It is used to connect Toshiba's various types of control equipment.

### Field Network

The FL-net compatible Remote I/O station (FL654) is available, which enables to establish the FL-net remote I/O systems.

As the field network, the S2E supports open DeviceNet that is suited for distributed I/O system, and Toshiba's field network TOSLINE-F10.

**DeviceNet:** Open field network promoted by ODVA, which is used world wide. Because of the protocol called CSMA/NBA, real-time data linkage is possible although the bit rate is not so fast. Flexible wiring is also available.

**TOSLINE-F10:** Easy handling field network system for distributed I/O. Transmission speed can be selected either 750kbps or 250kpps.

## S2E I/O Expansion Configuration

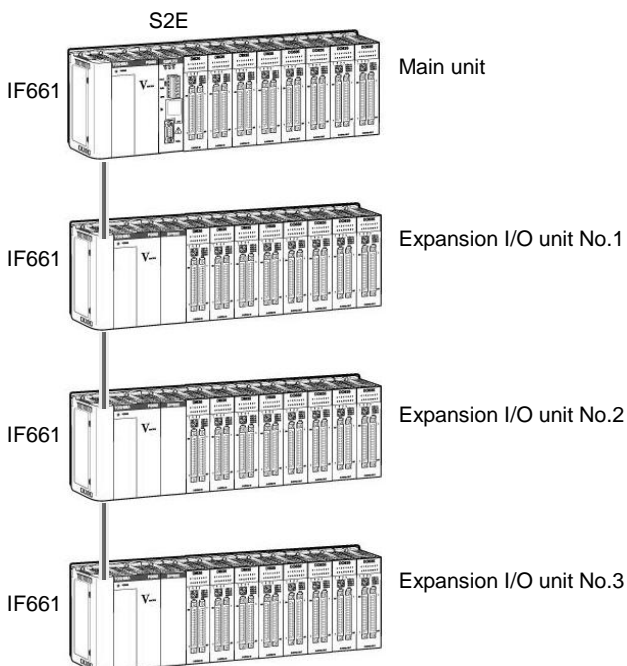

### I/O Expansion Configuration

Up to three I/O units can be connected to the S2E main unit. When connecting the I/O units, the expansion I/O interface IF661 is required in the left-end slot on both main units and expansion I/O units. Four types of expansion cables are available in the length, 0.3m, 0.5m, 0.7m and 1.2m. Select the cable length depending on the unit layout. (Cable total length = max. 3.6m)

The following three types of bases are available. Each base can be used for both main and expansion units.

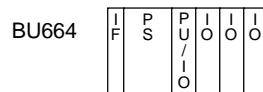
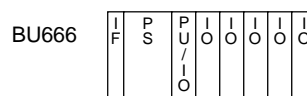
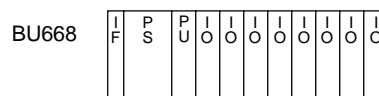

IF: IF661 slot  
 PS: Power supply slot  
 PU: S2E CPU slot  
 PU/IO: CPU or I/O slot  
 IO: I/O slot

When four BU668 are used for all main and expansion I/O units, total max. 32 I/O modules can be mounted. If 64 points I/O modules are used for all the available slots, the S2E can control max. 2048 points of I/O. It is the maximum local I/O points of the S2E.

## Features

### T-series Compatible

The S2E is compatible with T-series PLCs in application program. The T-series programming tool T-PDS is used for the S2E. Your T-series application program can be loaded and run without any conversion.

The I/O signal connections are also the same between the S2E I/Os and T2 I/Os. (32 points DI/DO module connectors are different)

### High-speed Processing

S2E's multi-processor configuration, a 32-bit microprocessor for overall control and a special designed language processor, enables high-speed program scan and minimum over head processing time.

Contact instruction: 0.11μs  
 Coil instruction: 0.22μs  
 16-bit transfer: 0.65μs  
 16-bit addition: 1.08μs

The S2E is about 4 to 10 times faster than T2E.

### High Performance

The S2E supports 24 types basic ladder instructions and 206 types of function instructions. The S2E can be applied to complex control systems. Off course the S2E supports floating-point mathematical functions that are required at process control applications. Also, the S2E has multi-task functions, main program, timer interrupt program and sub programs. Using the multi-task function, ideal control cycle for the control object can be achieved.

### Large Program Memory

It's a compact and economy type PLC, but it has 32K steps program memory. You can make a program without considering the memory limitation. Also, the S2E has a flash memory as well as the execution RAM. The application program and some constant data can be stored in the flash memory. So it is easy to recover in the event of RAM memory corruption.

### Multiple Programming Languages

In addition to the Ladder Diagram (LD) that is suitable for logic control, the S2E supports Sequential Function Chart (SFC) that can express sequential operations visually. By using the SFC, your program becomes easy to understand. It makes the program maintenance easy.

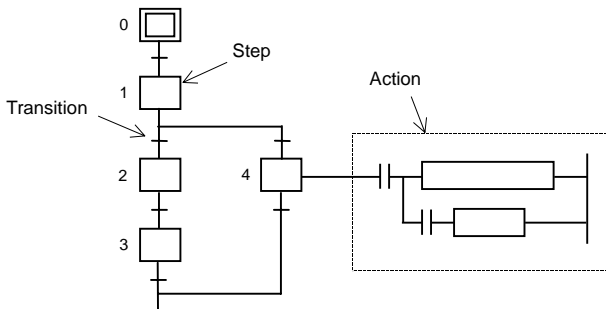

### Comment Storage in S2E CPU

The device name and comments can be stored in the S2E program memory. Without need of the source program, you can monitor and edit the S2E's program with displaying comments. It makes easy to modify the program at the site.

Note) To store the comments in the S2E's program memory, select the short type comment (Device name = 5 characters, Comments = 20 characters). The block and rung comments cannot be stored in the S2E's memory.

### Debug Support Functions

The S2E supports useful on-line debug support functions, such as input force, coil force, data set, sampling trace, status latch, etc. These on-line debug support functions greatly contribute to reduce the system testing time.

Sampling trace: Collects the data of the user-specified devices and registers at the user-specified sampling interval (minimum 1 scan). The collected data can be viewed as historical trend graph. (Max. 7 registers and 8 devices)

Status latch: Collects the data of the user-specified devices and registers at the moment of the user-specified condition is fulfilled. (Max. 32 registers/devices)

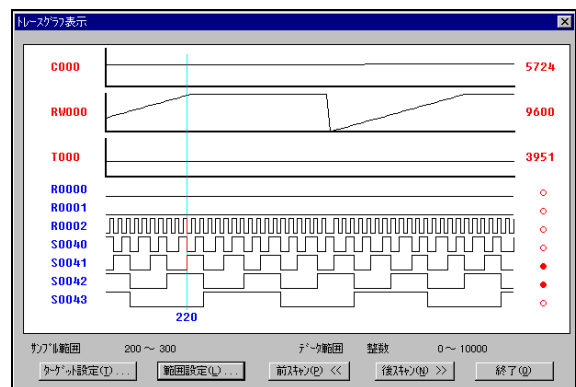

(Sampling trace screen example)

### Built-in Serial Communication Function

The S2E has an RS485 serial communication port in its CPU module. Either computer link mode or free ASCII mode can be selected. With the computer link mode, an upper level computer or human-machine interface (HMI) station can be connected. With the free ASCII mode, the S2E can communicate with serial ASCII devices, such as bar-code reader, weigh scale, etc.

Note) In the free ASCII mode, the communication message must be ASCII code with fixed trailing code.

### High-precision Machine Control

In order to meet the advanced machine control requirements, the S2E supports the 4-axis position control module MC614. The MC614 is a pulse output type position control module used with servo motors. It can configure high-speed and high-precision machine control systems. The pulse output rate of the MC614 is max. 1.3Mpps. 2-axis linear interpolation or circular interpolation is available as well as 4-axis independent operation.

Furthermore, the S2E supports the interrupt generation modules (CD633, PI632, etc.) that enable high-speed response independent of the CPU scan cycle.

### Process Control

The S2E has floating-point function instructions, such as PID, dead band, exponential function, trigonometric functions, etc., which are required for process control. Also, 8-channel isolated analog input modules (AD628S/628S) and 4-channel isolated analog output modules (DA624S) are available. These channel-isolated analog I/O modules can contribute to reduce the total system cost. The DA624S also has the output hold function in the event of S2E error. Some process control applications require this function for safety operation.

# Support Software

## Programming Tool T-PDS

The T-series programming tool T-PDS is a software package that runs on any Windows PC. The T-PDS supports S2E in every phase from application program designing to maintenance.

### Main features

- A full-feature program edition that includes cut & paste, search & replace, insert, delete, etc.
- Real-time on-line trace monitor function that can watch data in the PLC scan.
- Useful debug support functions, such as force I/O, sampling trace, etc.
- Event history function that is useful for troubleshooting or preventive maintenance.
- Multi-level password function for security.
- Part programming and block merge that enables group engineering.
- Program monitor, edit, and documentation with comments.
- Remote connection through Ethernet, TOSLINE-S20, or telephone line via modem. (In case of S2E, Ethernet connection is not possible)

### Latest version and operation platform

Name	Language	Version	Platform
T-PDS32 for Windows	English	2.20	Windows 95/98/Me/NT/2000/XP

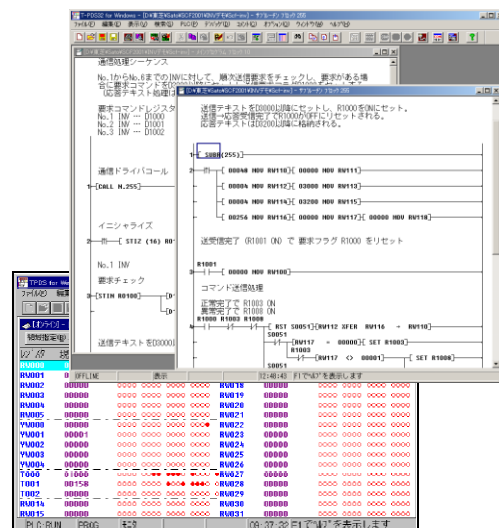

## TOSLINE-S20 Configuration Tool S-LS

The S-LS is the configuration tool for the control network TOSLINE-S20/S20LP. It is used to set the network parameters and to monitor the operation.

### Main features

- Direct connection to the TOSLINE-20/S20LP station's RS232C port.
- Parameters setting for every station on the network by one point connection.
- Useful system checking functions, such as scan data access, station connection status monitor, RAS information monitor, loop-back test.

### Latest version and operation platform

Name	Language	Version	Platform
S-LS for Windows	English	2.1	Windows 95/98/Me/NT/2000/XP

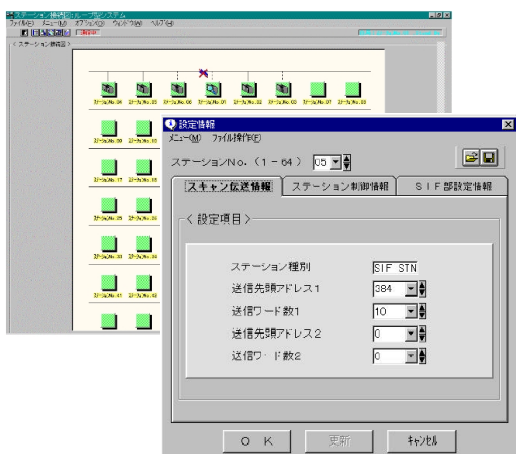

## DDE Server T-PSV

The T-PSV is a DDE server software that supports communication with the S2E using the computer link protocol. It runs on any Windows PC. The T-PSV collects the data from the connected S2E, and serves to the Windows applications such as Excel, etc., using DDE. Data writing into the S2E from the Windows application is also possible. The T-PSV is connected with PLCs through Ethernet, RS485 serial, or RS232C programmer port direct. (In case of S2E, Ethernet connection is not possible)

### Main features

- Easy data monitoring on a Windows PC.
- Data writing into PLC using VBA macro.
- Total max. 4096 words and for one PLC max. 744 words.
- Data gathering interval min. 0.2 sec. (depends on connection type)

### Latest version and operation platform

Name	Language	Version	Platform
T-PSV	English	1.1	Windows 98/Me/NT/2000

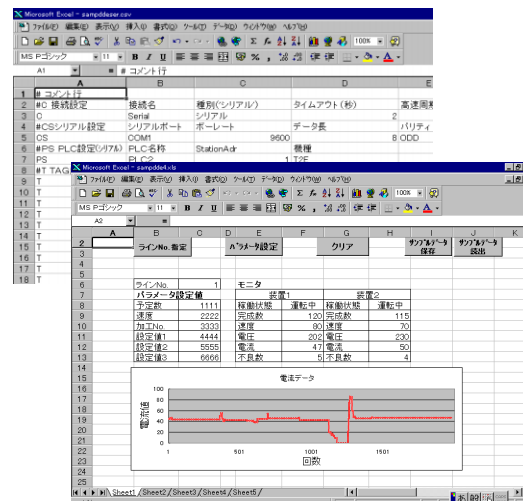

## General Specifications

### Power Supply

Item	PS693	PS632	PS652
Rated input voltage	100 to 240Vac (50/60Hz)	24Vdc	100 to 110Vdc
Allowable voltage range	85 to 264Vac (47~63Hz)	20.4 to 28.8Vdc	85 to 120Vdc
Power consumption	120VA (50W) or less	50W or less	50W or less
Retentive power interruption	1 cycle (20ms) or less	1ms or less	1ms or less
Allowable wave distortion	10% or less	-	-
Output capacity	5V-7A, 3.3V-1A, External 24V-0.8A (Total 35W or less)	5V-7A, 3.3V-1A (Total 35W or less)	5V-7A, 3.3V-1A (Total 35W or less)
Other function	RUN contact output (contact close at RUN, max. 240Vsc/24Vdc-0.2A)		

### Environment

Item	Specification
Operation temperature	0 to 55°C
Storage temperature	-20 to 70°C
Humidity	5 to 95%RH (no condensation)
Dust	10mg/m <sup>3</sup> or less
Atmosphere	No corrosive gas, no flammable gas
Vibration immunity	IEC61131-2 (10 to 150Hz, 9.8m/s <sup>2</sup> )
Shock immunity	IEC61131-2 (150m/s <sup>2</sup> )
Noise immunity	Power impulse: 1500Vp-p 1μs ESD: 8kV EMC directive
Insulation resistance	50MΩ or more (between external and internal circuits)
Withstand voltage	1500Vac for 1 minute
Grounding	100Ω or less (type D grounding)
Cooling	Natural air cooling

### Dimensions

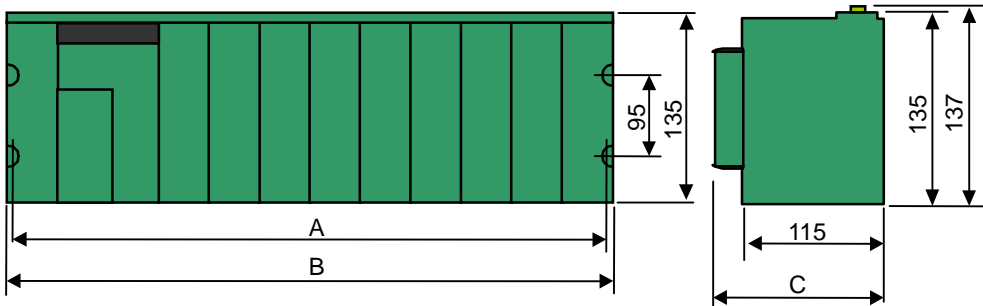

	BU668	BU666	BU664
A	402.5	295.5	224.5
B	417	309.5	238.5

	Terminal block	Connector
C	143	169

[mm]

## Functional Specifications

### Functional Specifications

Item		Specification	
<b>Control method</b>		Stored program cyclic scan method	
<b>Processor</b>		Overall control: 32-bit microprocessor Instruction execution: Special designed language processor (LP)	
<b>I/O method</b>		Batch I/O (refresh with main task), direct I/O, or combination	
<b>Number of I/O points</b>		1024 points (when 32 points I/O used) 2048 points (when 64 points I/O used) Local I/O memory: 8192 bits/512 words (1 word = 16 bits)	
<b>Application program</b>	<b>Programming language</b>	Ladder diagram (relay symbol + function block) Sequential Function Chart (SFC)	
	<b>Program capacity</b>	32K steps (including comments)	
	<b>Memory</b>	Main memory: SRAM (battery back-up) Auxiliary memory: Flash memory	
	<b>Instruction set</b>	Basic ladder instructions: 24 types Function instructions: 206 types <ul style="list-style-type: none"> <li>• Sequence (contact, coil, timer, counter, etc.)</li> <li>• Data transfer (single word / double word, register table)</li> <li>• Arithmetic (single word / double word, binary / BCD, signed / unsigned, floating-point)</li> <li>• Logic operation (single word/double word, register table, bit table)</li> <li>• Compare (single word / double word, signed / unsigned, floating-point)</li> <li>• Program control (jump, For-Next, subroutine, SFC, etc.)</li> <li>• Functions (limit, trigonometric, square root, integral, PID, function generator, etc.)</li> <li>• Conversion (ASCII, BCD, 7-Seg, double word integer / floating-point real)</li> <li>Others</li> </ul>	
	<b>Execution speed</b>	0.11μs / contact, 0.22μs / coil 0.65μs / transfer, 1.08μs / addition, 17.3μs / floating-point addition	
<b>Scan system</b>		Floating scan or constant scan (constant: 10 to 200ms, 10ms units)	
<b>Multi-tasking</b>		1 Main program 4 Sub-program (1 initial task fixed) 1 Timer interrupt (interval: 1 to 1000ms, 1ms units) 8 I/O interrupt (task switch 500μs or less) 256 Subroutines	
<b>User data</b>	<b>I/O relay/register</b>	8192 points / 512 words (X/Y or XW/YW: batch I/O, I/O or IW/OW: direct I/O)	
	<b>Auxiliary relay/register</b>	16000 points / 1000 words (R/RW)	
	<b>Special relay/register</b>	4096 points / 256 words (S/SW)	
	<b>Timer relay/register</b>	1000 points (T/T) (10ms timer or 100ms timer: user setting, default: 64 10ms timer)	
	<b>Counter relay/register</b>	512 points (C./C)	
	<b>Data register</b>	8192 words (D)	
	<b>Link relay/register</b>	16000 points / 2048 words (Z/W) for TOSLINE-S20 (leading 1000 words: bit access possible)	
	<b>Link relay/register</b>	4096 points / 256 words (L/LW) for TOSLINE-F10	
	<b>File register</b>	32768 words (F)	
	<b>Index register</b>	3 words (I, J, K)	
<b>Retentive memory</b>		User specified range for RW, T, C, D, and whole F registers	
<b>Real-time clock/calendar</b>		Year, month, day, day of the week, hour, minute, second (battery back-up)	
<b>Serial communication</b>	<b>Computer link port</b>	Interface	RS485 (4-wire)
		Bit rate	300, 600, 1200, 2400, 4800, 9600, 19200 bps
		Protocol	Computer link mode: T-series computer link protocol (ASCII/binary) Free ASCII mode: non-procedure (desired message, max. 512 bytes)
	<b>Programmer port</b>	Interface	RS232C
		Bit rate	9600 bps (fixed)
		Protocol	T-series computer link protocol (ASCII/binary) (available ASCII command: ST, DR, DW)
<b>RAS</b>	<b>Self-diagnosis</b>	Power interrupt check, battery voltage check, I/O bus check, I/O registration check, I/O response, I/O parity, watchdog timer, illegal instruction, LP check, others	
	<b>Monitoring</b>	Event history record, scan time measurement, constant scan delay, others	
	<b>Debug/maintenance</b>	On-line trace monitor, force function, sampling trace, status latch, others	

## Input / Output Specifications

### Digital Input

Item	DI633	DI634	DI635	DI635H
Module type	DC input, sink/source			
Input voltage	12 to 24Vdc/ac, +10/-15%	24Vdc, +10/-15%	24Vdc, +10/-15%	24Vdc, +10/-15%
Min. ON voltage	9.6V	16V	16V	16V
Max. OFF voltage	3.6V	5V	5V	5V
Input current	8mA (at 24Vdc)	4mA (at 24Vdc)	4mA (at 24Vdc)	4mA (at 24Vdc)
Input points	16 points (16/common)	32 points (8/common)	64 points (8/common)	64 points (8/common)
ON delay time	10ms or less (DC) 20ms or less (AC)	10ms or less	10ms or less	1.0ms or less
OFF delay time	10ms or less (DC) 15ms or less (AC)	15ms or less	15ms or less	1.5ms or less
Wire connection	Terminal block	Connector	Connector	Connector
Internal 5V power consumption	15mA	70mA	100mA	100mA

Item	DI632D	DI653	IN653	IN663
Module type	DC input, sink/source		AC input	
Input voltage	12 to 24Vdc/ac, +10/-15%	100 to 110Vdc, +10/-15%	100 to 120Vac, +10/15% (50/60Hz)	200 to 240Vac, +10/15%(50/60Hz)
Min. ON voltage	9.6V	84V	80Vac	160Vac
Max. OFF voltage	4.3V	22V	30Vac	60Vac
Input current	8mA (at 24Vdc)	2.3mA (at 100Vdc)	7mA (at 100Vac)	6mA (at 200Vac)
Input points	8 points (isolated)	16 points (8/common)	16points (16/common)	16points (16/common)
ON delay time	10ms or less (DC) 20ms or less (AC)	10ms or less	20ms or less	20ms or less
OFF delay time	10ms or less (DC) 15ms or less (AC)	10ms or less	15ms or less	15ms or less
Wire connection	Terminal block	Terminal block	Terminal block	Terminal block
Internal 5V power consumption	100mA	100mA	15mA	15mA

### Digital Output

Item	DO633	DO634	DO635	DO633P
Module type	DC output, sink			DC output, source
Output voltage	5 to 24Vdc, +10/-5%	5 to 24Vdc, ±10%	5 to 24Vdc, ±10%	12 to 24Vdc, +10/-5%
Load current	1A/point (12/24V) 0.3A/point (5V) 1.2A/4 points	0.1A/point (12/24V) 0.05A/point (5V)	0.1A/point (12/24V) 0.05A/point (5V)	1A/point (12/24V) 1.2A/4 points
Output points	16 points (16/common)	32 points (8/common)	64 points (8/common)	16 points (16/common)
ON delay time	1ms or less	1ms or less	1ms or less	1ms or less
OFF delay time	1ms or less	1ms or less	1ms or less	1ms or less
Leakage current	0.1mA or less (24Vdc)	0.1mA or less (24Vdc)	0.1mA or less (24Vdc)	0.1mA or less (24Vdc)
Wire connection	Terminal block	Connector	Connector	Terminal block
Internal 5V power consumption	60mA	150mA	250mA	60mA

Item	RO663	RO662S	AC663
Module type	Relay contact output, NO contact		AC output
Output voltage	24Vdc, +20% (max) 240Vac, +10% (max)	24Vdc, +20% (max) 240Vac, +10% (max)	100 to 240Vac, +10/-15% (50/60Hz)
Load current	2A/point (resistive load) 8A/common	2A/point (resistive load)	0.5A/point 0.6A/2 points
Output points	16 points (8/common)	8 points (isolated)	12 points (4/common)
ON delay time	10ms or less	10ms or less	1ms or less
OFF delay time	15ms or less	15ms or less	1/2 cycle + 1ms or less
Leakage current	None	None	1.2mA or less (at 100Vac) 3mA or less (at 240Vac)
Wire connection	Terminal block	Terminal block	Terminal block
Internal 5V power consumption	80mA	40mA	300mA

## Input / Output Specifications

### Analog Input

Item	AD624L	AD634L	AD624	AD674
Input signal	1 to 5V, 4 to 20mA	0 to 10V	1 to 5V, 4 to 20mA	±10V
Input impedance	Voltage: 500kΩ or more Current: 250Ω	500kΩ or more	Voltage: 1MΩ or more Current: 250Ω	1MΩ or more
Input channels	4 channels	4 channels	4 channels	4 channels
Resolution	8 bit (0 to 250)	8 bit (0 to 250)	12 bit (0 to 4000)	12 bit (-2000 to 2000)
Conversion cycle	1ms/4 channels	1ms/4 channels	2ms/4 channels	2ms/4 channels
Overall accuracy	±1%FS (0 to 55°C)	±1%FS (0 to 55°C)	±0.5%FS (25°C) ±1%FS (0 to 55°C)	±0.5%FS (25°C) ±1%FS (0 to 55°C)
Internal 5V power consumption	50mA	50mA	50mA	50mA

Item	AD628S	AD638S	AD668
Input signal	0 to 5V, 0 to 20mA	±10V	±5V, ±10V, 0 to 5V, 0 to 10V, 1 to 5V, 0 to 20mA, 4 to 20mA
Input impedance	Voltage: 500kΩ or more Current: 250Ω	500kΩ or more	Voltage: 1MΩ or more Current: 250Ω
Input channels	8 channels (isolated)	8 channels (isolated)	8 channels
Resolution	12 bit (0 to 4000)	12 bit (-2000 to 2000)	16 bit (-32000 to 32000) (FS: ±10V)
Conversion cycle	2ms/8 channels	2ms/8 channels	1ms/channel (8ms/8 channels)
Overall accuracy	±0.2%FS (25°C) ±1%FS (0 to 55°C)	±0.2%FS (25°C) ±1%FS (0 to 55°C)	±0.2%FS (25°C) ±0.5%FS (0 to 55°C)
Internal 5V power consumption	600mA	600mA	300mA

### Temperature Input

Item	TC618		RT614
Input signal	Thermocouple K, J, E		±100mV
Temperature input range	K: -200 to 1200°C J: -200 to 800°C E: -200 to 600°C		-50 to 270°C
Input channels	7 channels (1ch for CJC)	8 channels	4 channels
Resolution	16 bit (0.05°C/count)	16 bit (-32000 to 32000)	12 bit (0.1°C/count)
Conversion cycle	1ms/channel (8ms/8 channel) (averaging available)		200ms/4 channels
Overall accuracy	±0.2%FS (25°C), ±0.5%FS (0 to 55°C)		±0.3%FS (25°C)
Internal 5V power consumption	300mA		500mA

### Analog Output

Item	DA622L	DA622	DA672
Output signal	1 to 5V, 4to 20mA	1 to 5V, 4to 20mA	±10V
Load impedance	Voltage: 5kΩ or more Current: 600Ω or less	Voltage: 5kΩ or more Current: 600Ω or less	5kΩ or more
Output channels	2 channels	2 channels	2 channels
Resolution	8 bit (0 to 250)	12 bit (0 to 4000)	12 bit (-2000 to 2000)
Conversion cycle	1ms/2 channels	1ms/2 channels	1ms/2 channels
Overall accuracy	±1%FS (0 to 55°C)	±0.5%FS (25°C) ±1%FS (0 to 55°C)	±0.5%FS (25°C) ±1%FS (0 to 55°C)
Internal 5V power consumption	70mA	170mA	170mA

Item	DA664	DA624S
Output signal	±5V, ±10V, 0 to 5V, 0 to 10V, 1 to 5V, 0 to 20mA, 4 to 20mA	0 to 20mA
Load impedance	Voltage: 1kΩ or more, current: 600Ω or less	550Ω or less
Output channels	4 channels	4 channels (isolated)
Resolution	16 bit (-32000 to 32000) (FS: ±10V)	16 bit (0 to 64000)
Conversion cycle	1ms/channel (4ms/4 channels)	1ms/4 channel or less
Overall accuracy	±0.2%FS (25°C) ±0.5%FS (0 to 55°C)	±0.2%FS (25°C) ±0.5%FS (0 to 55°C)
Output at PLC error	-	Output hold or reset (selectable)
Internal 5V power consumption	230mA	220mA

## Input / Output Specifications

### Pulse Input

Item	PI632	PI672
Input channels	2 channels (phase A, B, M)	2 channels (phase A, B, M)
Input voltage	5/12/24V, ±5%	Conforms to RS422
Input current	15.5mA (5V), 15mA (12V), 12.5mA (24V)	
Input pulse rate	Max. 100kpps (other than quadrature) Max. 50kpps (quadrature)	Max. 100kpps (other than quadrature) Max. 50kpps (quadrature)
Counting rate	Max. 200k count/sec	Max. 200k count/sec
Count value	24-bit binary (0 to 16777215)	24-bit binary (0 to 16777215)
Counter operation mode	Quadrature bi-pulse counter (90° phase shift), up/down counter (phase A = up / phase B = down), auto-reset universal counter, speed counter, programmable interval timer, gate ON timer	
Interrupt function	Interrupt generation at count match with preset (main unit only)	
Internal 5V power consumption	500mA	650mA

### Change Detect DC Input

Item	CD633
Input voltage	12 to 24Vdc, +10/-15%
Min. ON voltage	9.6V
Max. OFF voltage	3.6V
Input current	7mA (at 24Vdc)
Input points	16 points (16 points/ common)
ON delay time	1ms or less
OFF delay time	1ms or less
Interrupt function	Interrupt generation at input signal state changing* (main unit only) * signal state changing: rising / falling / both (user setting)
Internal 5V power consumption	200mA

### Position Control

Item	MC612	MC614
Number of axis	2 axis	4 axis
Control method	Pulse train output	Pulse train output
Axis control	Each axis independent, 2 axis linear interpolation	Each axis independent, 2 axis linear interpolation, 2 axis circular interpolation
Control units	Pulse, mm, inch, degree, etc.	Pulse
Positioning range	±9,999,999 (control units)	-134,217,727 to +134,217,726
Pulse output speed	Max. 200kpps	Max. 1.3Mpps
Pulse output method	CW/CCW or pulse + direction	CW/CCW or pulse + direction
Pulse output signal	5 to 24Vdc (50mA), RS422	RS422
Acc/dec system	Automatic trapezoidal	Automatic trapezoidal / automatic S curve
Operation mode	Zero return, Jog, fix feed, direct positioning, point No operation, automatic stepping, jog/position switch, interrupt positioning	Zero return, Jog, direct positioning, point No operation, automatic stepping, pulsar input operation
Other functions	Electric gear, over ride, position change, back-rash compensation, teaching, feed-back pulse input (for monitoring)	Over ride, position change, back-rash compensation, teaching
Internal 5V power consumption	700mA	700mA

### Communication Interface

Item	CF611
Interface	RS232C, 1 port
Transmission mode	Full duplex
Synchronizing	Start-stop method (asynchronous)
Protocol	Non-procedure (trailing code detection)
Bit rate	300, 600, 1200, 2400, 4800, 9600, 19200 bps
Code	ASCII (7 or 8 bits)
Message length	Max. 320 byte
Connectable device	Computer, bar-code reader, display device, sensor, printer, or other serial ASCII devices
Signal connection	D-Sub 9-pin connector (female)
Internal 5V power consumption	550mA

## Part numbers

### S2E Basic Components

Name	Description	Type	Part number
S2E CPU module	32K steps, built-in RS485 port	PU612E	GPU612E*S
Power supply module	100 to 240Vac input	PS693	GPU693**S
	24Vdc input	PS632	GPS632**S
	100 to 110Vdc input	PS652	GPS652**S
Base (main/expansion common)	Main: 8 I/Os / Expansion: 8 I/Os	BU668	GBU668**S
	Main: 5 I/Os / Expansion: 6 I/Os	BU666	GBU666**S
	Main: 3 I/Os / Expansion: 4 I/Os	BU664	GBU664**S
Expansion I/O interface	Parallel I/O bus 1 line (main/expansion common)	IF661	GIF661**S

### I/O Modules

Name	Description	Type	Part number
DC input	8 points (isolated), 12-24Vdc/ac input	DI632D	GDI632D*S
	16 points, 12-24Vdc/ac input	DI633	GDI633**S
	32 points, 24Vdc input	DI634	GDI634**S
	64 points, 24Vdc input	DI635	GDI635**S
	64 points, 24Vdc input (high-speed)	DI635H	GDI635H*S
	16 points, 100-110Vdc input	DI653	GDI653**S
AC input	16 points, 100-120Vac input	IN653	GIN653**S
	16 points, 200-240Vac input	IN663	GIN663**S
DC output	16 points, 24Vdc output, 1A/point	DO633	GDO633**S
	16 points, 24Vdc output, 1A/point (current source)	DO633P	GDO633P*S
	32 points, 24Vdc output, 0.1A/point	DO634	GDO634**S
	64 points, 24Vdc output, 0.1A/point	DO635	GDO635**S
AC output	12 points, 100-240Vac output, 0.5A/point	AO663	GAC663**S
Relay contact output	16 points, 240Vac/24Vdc output, 2A/point	RO663	GRO663**S
	8 points (isolated), 240Vac/24Vdc output, 2A/point	RO662S	GRO662S*S
Analog input	4 channels, 1-5V / 4-20mA, 8 bit	AD624L	GAD624L*S
	4 channels, 0-10V, 8 bit	AD634L	GAD634L*S
	4 channels, 1-5V / 4-20mA, 12 bit	AD624	GAD624**S
	4 channels, $\pm 10V$ , 12 bit	AD674	GAD674**S
	8 channels, 0-5V / 1-5V / $\pm 5V$ / $\pm 10V$ / 0-20mA / 4-20mA, 16 bit	AD668	GAD668**S
	8 channels (isolated), 0-5V / 0-20mA, 12 bit	AD628S	GAD628S*S
	8 channels (isolated), $\pm 10V$ , 12 bit	AD638S	GAD638S*S
RTD input	4 channels, Pt100 input, 12 bit	RT614	GRT614**S
Thermocouple input	8 channels, K / J / E / $\pm 100mV$ , 16 bit	TC618	GTC618**S
Analog output	2 channels, 1-5V / 4-20mA, 8 bit	DA622L	GDA622L*S
	2 channels, 1-5V / 4-20mA, 12 bit	DA622	GDA622**S
	2 channels, $\pm 10V$ , 12 bit	DA672	GDA672**S
	4 channels, 0-5V / 1-5V / $\pm 5V$ / $\pm 10V$ / 0-20mA / 4-20mA, 16 bit	DA664	GDA664**S
	4 channels (isolated), 0-20mA, 16 bit (output hold available)	DA624S	GDA624S*S
Pulse input	2 channels, 100kpps, 5/12/24Vdc (interrupt generation)	PI632	GPI632**S
	2 channels, 100kpps, RS422 (interrupt generation)	PI672	GPI672**S
Change detect DC input	16 points, 12-24Vdc input (interrupt generation)	CD633	GCD633**S
Position control	2 axis, pulse output, 200kpps, independent / linear interpolation	MC612	GMC612**S
	4 axis, pulse output, 1.3Mpps, independent / linear / circular interpolation	MC614	GMC614**S
Communication interface	RS232C 1 port, ASCII non-procedure	CF611	GCF611**S

### Network Modules

Name	Description	Type	Part number
FL-net	FL-net controller station (Ver.2.0)	FL612	GFL612**S
	FL-net remote I/O station (Ver.2.0)	FL654	GFL654**S
TOSLINE-S20	TOSLINE-S20 co-axial bus	SN621	GSN621**S
	TOSLINE-S20 optical bus	SN622	GSN622**S
DeviceNet	Scanner	DN611A	GDN611A*S
TOSLINE-F10	Master station	UN611	GUN611**S
	Remote station	UN612	GUN612**S

### Cables

Name	Description	Type	Part number
I/O expansion cable	0.3m length	CS6R3	GCS6R3*CS
	0.5m length	CS6R5	GCS6R5*CS
	0.7m length	CS6R7	GCS6R7*CS
	1.2m length	CS6*1	GCS6*1*CS
T-PDS connection cable	5m length	CJ905	TCJ905*CS

### Support Software

Name	Description	Type	Part number
Programming tool	Windows95/98/Me/NT/2000/XP (English), CD-ROM version	TPDS32	TMW3CE2SS
S20 configuration tool	Windows95/98/Me/NT/2000/XP (English)	S-LS	SMW23E*SS
DeviceNet Wizard	DeviceNet Wizard for TOSHIBA (English)	-	TDW33E2SS
DDE server	Windows98/Me/NT/2000 (English)	T-PSV	TPV33E2SS

### Miscellaneous

Name	Description	Type	Part number
Vacant slot cover	Blank module for vacant slot	SP600	GSP600**S
Battery	Spare lithium battery	BT611	GBT611*AS

---

#### Trademarks

- Microsoft, Windows, WindowsNT are registered trademarks of Microsoft Corporation.
- The official name of Windows is Microsoft Windows Operating System.
- Ethernet is a registered trademark of Xerox Corporation.
- DeviceNet is a registered trademark of ODVA.
- Names for products in this catalog may be registered trademarks of their respective manufacturers or developers.



### Safety Precaution

This product is intended to be used for the control of industrial machines and processes. Misuse of this product can result in property damage or human injury. Read related manuals carefully before using this product.  
In no event will Toshiba Corporation be responsible or liable for either indirect or consequential damage or injury that may result from the use of this product.



# TOSHIBA

**TOSHIBA CORPORATION**

**Industrial and Power Systems & Services Company**

Electrical Apparatus & Measurement Division

1-1, Shibaura 1-chome, Minato-ku, Tokyo 105-8001, Japan

Tel: (03)3457-4894 Fax: (03)5444-9409

URL: <http://www3.toshiba.co.jp/sic/english/seigyo/vseries/>

For further information, please contact your nearest Toshiba Representative.  
The data given in this catalog are subject to change without notice.