



MARINE PRODUCT GUIDE



JANUARY 2011



ENGINEERED TO WORK. REAL HARD.

Twin Disc marine products are designed, engineered and built to perform real tasks, really well, in the real world. Sometimes it's glamorous work; sometimes it's not so pretty. But it's always necessary.

From luxurious pleasure craft to stealthy military vessels to hard working tugs, pushboats, fishing boats, crew boats and supply vessels. Twin Disc products optimize the control of the engine's horsepower, contributing to the boat's overall performance, productivity, operating efficiency and cost-effectiveness.

Twin Disc marine products propel all kinds of vessels, on all kinds of water, all around the world.

TABLE OF CONTENTS

Twin Disc Marine Product Information	3-18
Service Classification Definitions	19
Important Application Information	20
Pleasure Craft	21-30
Standard and QuickShift® Marine Transmission Ratings	
Light Duty	31-38
Standard and QuickShift® Marine Transmission Ratings	
Intermediate Duty	39-50
Standard and QuickShift® Marine Transmission Ratings	
Medium Duty	51-60
Standard and QuickShift® Marine Transmission Ratings	
Continuous Duty	61-72
Standard and QuickShift® Marine Transmission Ratings	
Standard and QuickShift® Marine Transmission Dimensions	73-78
Twin Disc Locations	81-82

NOTHING ELSE COMES CLOSE.

It took the vision and determination of acknowledged mechanical innovator and offshore racing enthusiast Howard Arneson to perfect the performance and reliability of *surface-piercing propulsion*. It took Twin Disc to further realize the extraordinary capabilities of Arneson Surface Drives for non-racing capabilities — pleasure craft and commercial vessels, as well as military applications.

No other marine propulsion system is so adaptable to such a wide range of engine sizes and types. There's an Arneson model designed specifically to fit virtually every powerplant option, accommodating torque outputs exceeding 30,000 lb-ft.

Arneson Surface Drives are the fastest, most efficient, fuel-friendly propulsion systems on the planet. When combined with Twin Disc QuickShift transmissions and EC300 control systems, Arneson surface drives allow you to control your vessel from almost 1 knot to full speed with just a single stroke of the lever.



MODEL		ASD06	ASD08	ASD 10	ASD 11S	ASD 12	ASD 14	ASD 15S	ASD 15L	ASD 16	ASD 18S	ASD 18L
HORSEPOWER ACCEPTANCE	GASOLINE @ 5200 rpm	To 550	To 990	To 1485	—							
	DIESEL @ 2400 rpm	To 290	To 380	To 565	To 850	To 1400	To 1800	To 2100	To 2400	Contact Twin Disc, Inc.		
	GAS TURBINE	To 10,000 (subject to application)										
ASD INPUT SHAFT TORQUE LIMITS ¹ (lbs-ft)		650	1200	2000	3200	4800	8000	11500	13500	16500	21500	30000
NOMINAL SHAFT SIZE (inches)		1.75	2.00	2.50	2.875	3.30	3.50	4.50	4.50	4.50	5.51	6.69
UNIT WEIGHT (pounds, dry, includes ASD unit, trim and steering cylinders, trim pump, reservoir, mounting hardware and hoses) ²		A 135 B 195	B 285	B 415	B 515	B 785	B 1135	A 1500	A 1540	A 1985	A 3200	A 4880
OVERALL EXTERNAL LENGTH (inches)		36	42	53	57	63	71	78	78	87	104	107
THRUST SOCKET DIAMETER (inches)		8	8	10	10	13	15	19	19	20	22.5	24
THRUST SOCKET FLANGE DIAMETER (inches)		8	12	14	14	17	19	21.25	21.25	23	29.5	29.5
TURNING ANGLE (total)		40°	40°	40°	40°	40°	40°	36°	36°	36°	29°	29°
PROPELLER TRIM CONTROL (vertical travel)		15°	15°	15°	15°	15°	15°	15°	15°	15°	15°	15°

¹ Torque ratings shown are nominal and may vary due to vessel characteristics.

2 A: Aluminum housings
B: Bronze housings



DON'T BUY YOUR NEXT BOAT WITHOUT EJS™

The Twin Disc EJS (Express Joystick System) absolutely revolutionizes docking and slow speed maneuvering of diesel powered, conventional shaftline boats.

With easy fingertip movements you control direction and speed — instantaneously and intuitively. No lugging. No lurching. No clunking. All thanks to proven QuickShift® transmission and EC300 control technology.

The EJS smoothly and simultaneously actuates and controls engines, transmissions and thrusters. You can effortlessly move the boat in any direction and even pivot it on its own axis. Its performance dramatically exceeds any other propulsion system. EJS brings incomparable control and enjoyment to even the most difficult docking situations. Once you try it, you can't imagine driving your next boat without it.

FEATURES

"Push, twist and go" directional maneuvering

Proven QuickShift transmission and EC300 control technologies

Simultaneously and instantaneously controls engines, transmissions and thrusters

During docking, eliminates steering wheel & control lever activities

Extremely intuitive responsiveness

Ergonomically friendly

Remarkably easy to learn

ULTIMATE CONTROL IN YOUR HANDS

Leading the industry in quality, style and performance, the Twin Disc Power Commander® electronic control system is designed to interface with all popular electronic engines and transmissions. It is versatile, rugged and easy to install. With literally one finger on one lever, the operator can control the boat's speed and direction. Multiple drivetrains and multiple control heads can easily be accommodated. And multiple electronic control stations can be placed around the boat.



EXPRESS JOYSTICK SYSTEM® (EJS™)

SAMPLE DIAGRAM

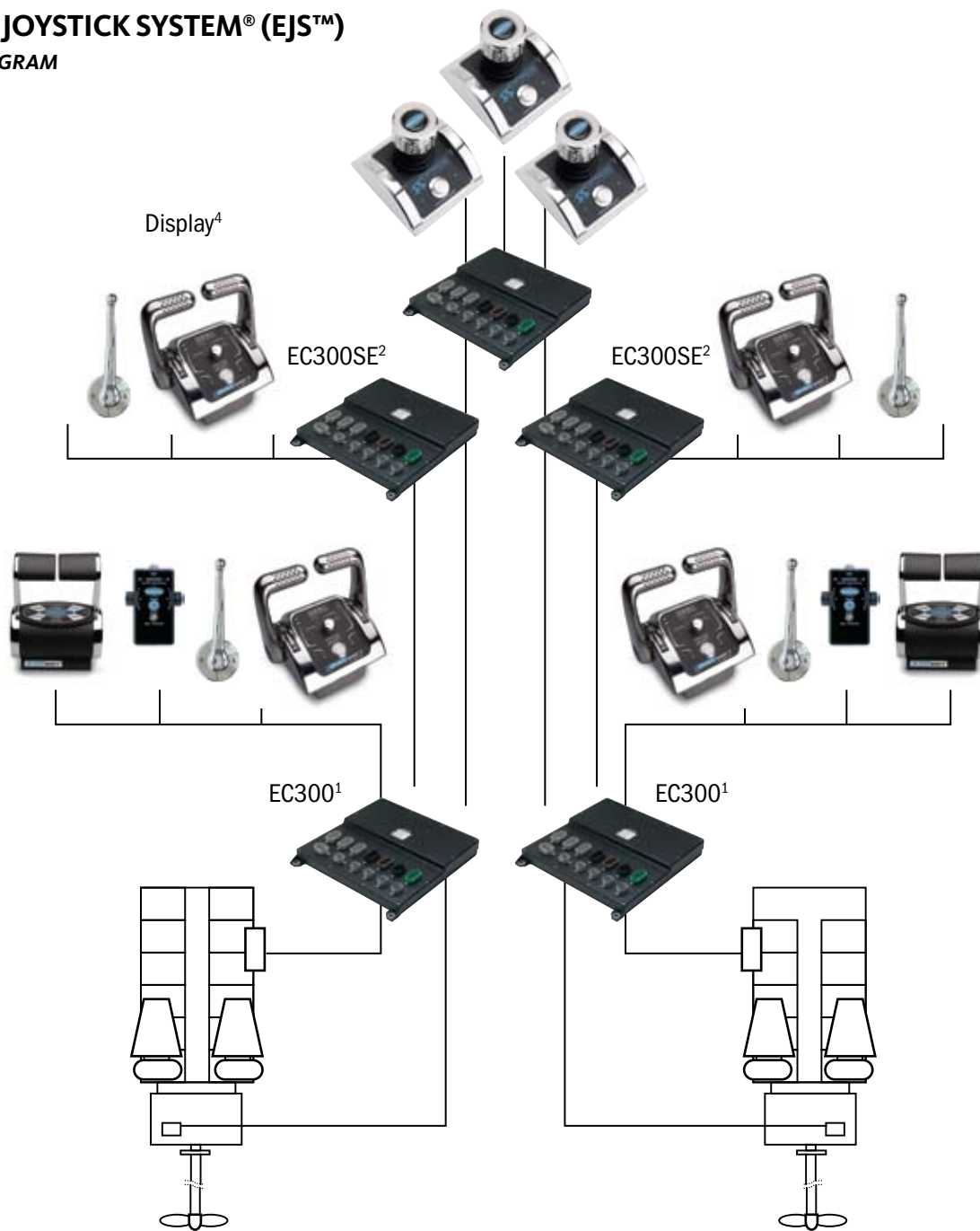

1 EC300: Standard control system for up to three analog stations or up to eight digital stations and up to eight engine/transmission shaft lines per vessel.

2 EC300SE: Station Expansion option for three additional full control stations.

3 EC300JS: Express Joystick System option for up to three joystick stations.

4 Display option for up to six stations, not available for joystick-only stations.

PLEASE CONTACT TWIN DISC OR A TWIN DISC AUTHORIZED DISTRIBUTOR FOR MORE DETAILS.

FEATURES

- Single lever control
- Upload or keyboard setup
- Selectable synchronization
- Trolling valve control option
- J1939, RS232, RS485 coms
- Allows up to five control stations
- Cast aluminum control boxes with cast aluminum bronze levers
- Express™ ready

ADVANTAGES

- Selectable station transfer rules
- Individual station active indicators
- Individual station neutral indicators
- 12 and 24 volt system power compatible



EC300DP POWER COMMANDER ELECTRONIC CONTROL SYSTEM

The Twin Disc EC300DP propulsion control package allows instantaneous, shockless and virtually constant forward and reverse shifting to keep supply vessels on station as directed by the craft's dynamic positioning system. Drivelines can execute directional reversals at variable torque levels more than 30 times per minute to hold station with the full requirements of the DP class.

FEATURES

- High thrust rate change competitive with alternative drive packages
- More than 30x/minute directional reversals
- Designed for conventional shaft lines
- Thrust control from 10% of idle engagement to full engine power
- Maintain fuel-efficient engine speeds even at low propeller speeds
- Rate of change of thrust direction meets DP2 requirements
- Enhanced installation, monitoring and maintenance/service software



TWIN DISC DP INTERFACE SYSTEM (EC300DP)

SAMPLE DIAGRAM

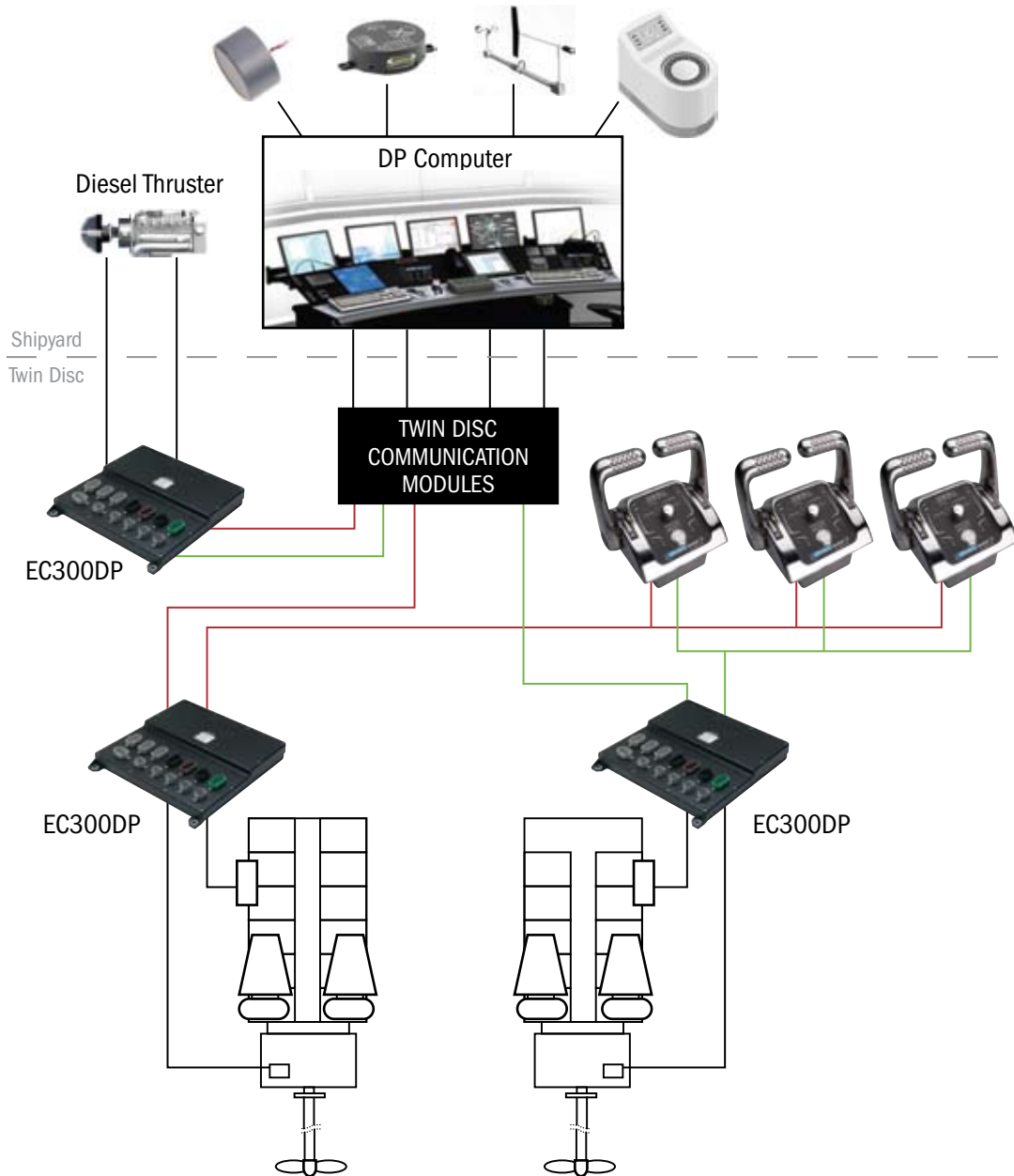

The Twin Disc EC300DP control system is suitable for DP0, DP1 and DP2 vessels with conventional propellers and up to four (4) engine/ transmission drivelines.

PLEASE CONTACT TWIN DISC OR A TWIN DISC AUTHORIZED DISTRIBUTOR FOR MORE DETAILS.

ROLLA

A Twin Disc Company

ULTIMATE PROPELLER PERFORMANCE.

Since 1963 the name Rolla has been synonymous with the highest quality, most efficient propellers in the world. What started with Philip Rolla individually designing and crafting race-winning propellers has grown to become the leader in propeller technology for high-performance pleasure and commercial craft as well as military vessels.

Rolla stainless steel and NiBrAl propellers range from 16 inches to 10 feet in diameter and are specifically designed for high-performance submerged and Arneson Surface Drive applications.

Rolla offers a wide variety of service for every aspect of propeller design, manufacture and application, from complete hydrodynamic analysis and engineering capabilities to computational fluid dynamic (CFD) hull analysis to sea trials.

TWIN DISC HYDRAULIC THRUSTERS



HYDRAULIC THRUSTER TECHNICAL DATA

MODEL	Nominal Thrust Kgf • N (lbs)	Tunnel I.D. mm (in)	Nominal Power kW (hp)	Weight kg (lbs)
BP 220	220 • 2158 (485)	250 (9.83)	18.7 (25)	24 (53)
BP 300	300 • 2943 (661)	300 (11.80)	28.5 (38)	35 (77)
BP 400	400 • 3924 (881)	355 (14)	35 (47)	45 (99)
BP 550	550 • 5886 (1322)	400 (15.75)	48.5 (65)	75 (165)
BP 600	600 • 5886 (1333)	450 (17.72)	60 (82)	85 (189)

These values shall be intended as indicative. The performances of each thruster depend on several different factors and on the sizing of the hydraulic components. Ask the Twin Disc Technical Department for suggestions on the most suitable configuration.

SAILBOAT HYBRID PROPULSION SYSTEM

The SeaProp60 saildrive is a propulsion system for sailboats with engines rated up to 56 kW (75 hp) @ 3600 rpm. Sailboat manufacturers and operators alike benefit from this system's unique but proven design.

With a SeaProp60 saildrive, the sailboat manufacturer will overcome inherent limitations and problems of conventional inboard shaft drive installations with a quicker, more versatile and simplified engine installation process.

Gone is the propeller shaft, along with its attendant coupling, stuffing box, cutless bearing, stern tube, and strut. Also eliminated are the alignment procedures required between the engine and shaft that must be done on the production line.

The SeaProp60 can easily be mounted facing forward or aft. Because it isn't constrained by shaft angle or aperture location, and it offers the builder more versatility in engine placement and a smaller 'footprint' (no shaft, shaft log, or strut aft of the engine).

Boat operation will benefit from increased propulsion efficiency with the SeaProp60 saildrive. Unlike conventional drivelines, thrust is parallel to the boat's waterline, whereas the downward angle on a standard shaft means that some of the propeller's thrust is wasted.

Experienced sailboat owners recognize saildrives are more efficient, quieter, offer much less vibration to the boat and provide all-around smoother running — not to mention the absence of water leaking into the bilge through the stuffing box.

SeaProp60 can be matched with a variety of fixed or foldable propellers.

SAIL DRIVE SP60 TECHNICAL DATA

RATIO		INPUT RATINGS - PLEASURE KW (HP)		
Forward	Reverse	2800 rpm	3000 rpm	3600 rpm
2.15	2.15	43 (59)	46 (63)	55 (75)
2.38	2.38	34 (46)	36 (50)	44 (60)

Max Input Speed: 3800 rpm
Dry Weight: 43 kg
Oil Quantity: 2.8 liters

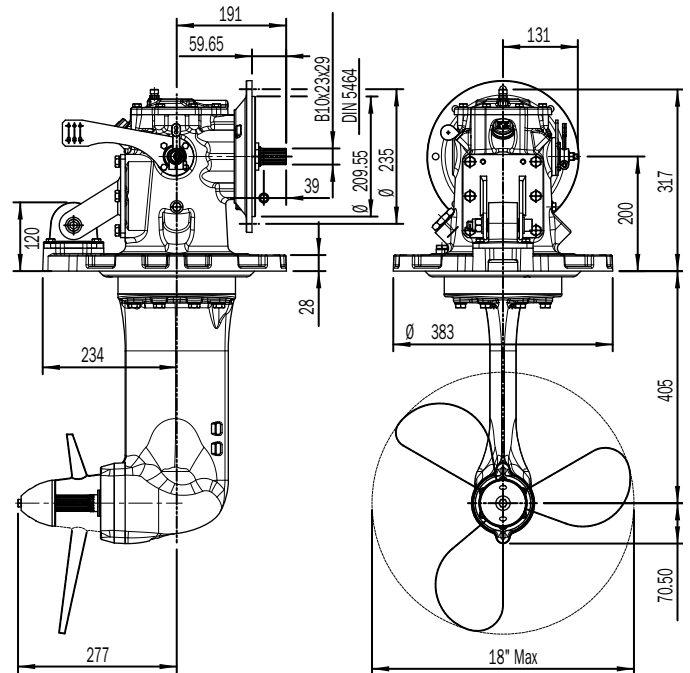



MARINE CONTROL DRIVE (MCD)

With over 30 years of research, development and operation, the versatile Twin Disc Marine Control Drive (MCD) has proven its worth in a wide variety of workboat applications, including tugs, offshore supply vessels, double-ended ferries, icebreakers, dredges and fire fighting vessels.

The MCD provides distinct operating advantages for any vessel requiring highly accurate positioning or extreme slow speed maneuverability while splitting main engine power to another operation — driving pumps, lifting cargo, hauling lines, turning generators. Often the MCD is used in conjunction with azimuth thruster. The MCD represents the best alternative to controllable pitch propellers (CPP).

ADVANTAGES

Smooth, gradual propeller speed change resulting in improved maneuverability

Safer and easier vessel control during slow speed maneuvering and docking

Adjustment of propeller speeds below engine speed rating

Divides the power from the main propulsion engine to eliminate the need for auxiliary engines

Delivers an instant response when required

Bearing calculated for high universal joint angles at max. power

Dynamic positioning (DP) capable

PTO to drive auxiliary equipment is standard

Emergency “come home” device per classification requirements

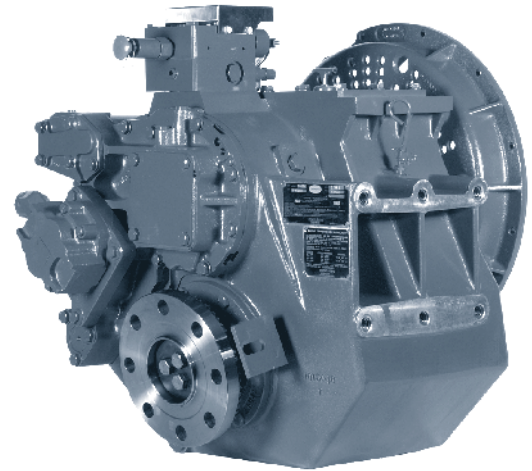

QUICKSHIFT®
You've got to feel it to believe it.

FAST, SMOOTH SHIFTS

No other marine transmission in the world shifts as fast and smooth as the Twin Disc QuickShift, yet it provides amazing control at near zero vessel speed.

INSTANT POWER TO PROPELLER

With its patented, completely internal and integrated clutch actuating system, QuickShift instantly delivers cushioned torque to the driveline when shifting from neutral to anywhere from full ahead to full reverse. It eliminates driveline shock while optimizing power to the driveshaft. And all this happens literally within milliseconds. So you have a steep but smooth power curve, whether you go full out or just nudge the throttle.

SUPERIOR MANEUVERING CONTROL

It's difficult for a powerful diesel vessel to go very slowly with a conventional transmission. Reducing engine rpm to reduce vessel speed to an acceptable and manageable speed is not possible or could stall the engine. Not so with QuickShift. It regulates engine torque at extremely low speeds to slow the propeller speed down to 50 rpm or less — allowing you to maneuver at near zero boat speed, an incredible advantage in docking.

SERVICE CLASSIFICATION DEFINITIONS

PLEASURE CRAFT

Up to 500 hours/year, low load factor usage planing hull vessels where typical full engine throttle operation is less than 10% of total time. The balance of operation at 80% of full engine throttle or less. Marine transmissions for use in long range pleasure cruisers, sportfish charter boats/patrol boats do not qualify for Pleasure Craft Service.

Note: Some revenue-producing applications such as Planing Hull Bristol Bay Gillnetter do qualify under Pleasure Craft rating definition.

LIGHT DUTY

Relatively low hour usage (less than 1500 hours/year) where full throttle operation is 2 hours out of 12. Typical applications include planing hull vessels such as fire boats, sport-fish charter boats, and patrol/customs boats. This rating is also applicable to some bow and stern thruster applications.

INTERMEDIATE DUTY

Hour usage of up to 2000 hours/year (for models MG-5114 and smaller) and up to 3000 hours/year (for models larger than MG-5114) with 50% of the operating time at full engine rating.

Typical applications include planing hull vessels such as ferries, fishing boats, some crew boats, and also some displacement hull yachts as well as some bow and stern thruster applications.

MEDIUM DUTY

Hour usage of up to 4000 hours/year with up to 80% of operating time at full engine power. This duty classification is for usage where some variations in engine speed/power occur as part of normal vessel operation.

Typical vessels include mid-water trawlers, crew/supply boats, ferries, and some inland water tow boats.

CONTINUOUS DUTY

For use in continuous operation with little or no variation in engine speed/power settings.

Typical vessels include fishing trawlers, tow/tug boats and ocean going vessels.

IMPORTANT APPLICATION INFORMATION

- Transmission ratings are based on use of the transmission in a torsionally compatible system utilizing a suitable input torsional coupling.
- Ratings are for diesel engines at the indicated speeds, unless otherwise indicated.
- Ratings are shown in SAE horsepower (HP).
- Consult factory for ratings applicable to gasoline engines, gas turbines, or other applications not conforming to the given service class definitions.
- Ratings apply to right hand engines (i.e., counter-clockwise flywheel rotation when viewing rear of engine).
- Ratings are full power forward or reverse except where specified by "F" (using forward gear train for forward).
- Transmission ratings should equal or exceed the engine's published ratings for the given application.
- Final marine transmission selections are to be confirmed prior to issuance of the purchase order. For unusual or unique applications, please contact Twin Disc, Inc. for product selection assistance.
- Marine transmission input couplings provided by Twin Disc are configured to interface with engine flywheels which conform to SAE J620 standards. Please consult Twin Disc when use of non-standard flywheels are contemplated.
- Most of the transmissions listed herein are to be mounted directly on the SAE flywheel housing of the engine. It is necessary that the engine crankshaft end-play be measured before the driven equipment is installed and rechecked after the driven equipment is installed. The endplay measurements, before and after transmission installation, should be the same. If not the same, the driven equipment should be removed and the problem source located and corrected before the engine is started. Engine crankshaft endplay measurement is considered mandatory.
- The given data is subject to modifications/corrections without prior notice.
- Use certified print for installation.

IMPORTANT NOTICE

Disregarding propulsion system torsional compatibility could cause damage to components in the drive train resulting in loss of mobility. At minimum, system incompatibility could result in gear clatter at low speeds.

The responsibility for ensuring that the torsional compatibility of the propulsion system is satisfactory rests with the assembler of the drive and driven equipment.

Torsional vibration analysis can be made by the engine builder, marine survey societies, independent consultants, and others. Twin Disc is prepared to assist in finding solutions to potential torsional problems that relate to the equipment of Twin Disc Incorporated's supply.

PLEASURE CRAFT RATINGS FOR STANDARD & QUICKSHIFT® MARINE TRANSMISSIONS



Model	Drawing Number	SAE Housing	Ratios	KILOWATTS (HORSEPOWER)			Maximum Speed (rpm)	Dry Weight (kg (lb))
				@ 2300 RPM	@ 2800 RPM	@ 3200 RPM		
MG-340	IT101317501	5, BW	1.45 2.00 2.60	26 (35) 21 (28) 17 (23)	26 (35) 26 (35) 21 (28)	26 (35) 26 (35) 23 (31)	4500	9 (20)
MG-360	IT101318505	5, BW	1.55 2.00 2.45 2.83	40 (54) 36 (48) 29 (39) 24 (32)	50 (67) 44 (59) 35 (47) 29 (39)	56 (75) 50 (67) 40 (54) 33 (44)	5000	14 (31)
MG-5005 A	IT345ATD0001	3, 4, 5	1.54 2.00 2.47	83 (111) 67 (90) 50 (67)	101 (136) 82 (110) 60 (81)	110 (148) 93 (125) 70 (94)	4500	25 (55)
MG-5012 SC	IT1013079B01	3, 4, BW	1.52 2.09 2.40 2.78	123 (165) 106 (142) 94 (126) 82 (110)	149 (200) 129 (173) 115 (154) 100 (134)	171 (229) 148 (198) 131 (176) 114 (153)	4500	53 (117)
MG-5020 SC	IT1013049B01	3, 4, BW	1.50, 2.04 2.50 2.94	181 (242) 145 (194) 123 (165)	220 (295) 176 (236) 150 (201)	251 (337) 201 (270) 171 (229)	4000	75 (165)
MG-5025 A	IT1013170	3, 4, BW	1.52, 2.09 2.40	115 (154) 100 (134)	140 (188) 123 (165)	160 (215) 140 (188)	4500	36 (79)
MG-5055 A	IT101316101	3, 4, BW	1.53, 2.08 2.60	214 (287) 144 (193)	261 (350) 176 (236)	298 (400) 201 (270)	4000	54 (119)
				@ 2300 RPM	@ 2500 RPM	@ 2800 RPM		
MG-5011 SC*	PX-10270	3, 4, BW	1.11, 1.27, 1.50, 2.00 2.44	164 (220) 145 (195)	177 (237) 157 (210)	186 (250) 168 (225)	4400	49 (109)
MG-5011 A*	PX-9999	3, 4, BW	1.44, 1.90 2.39	164 (220) 145 (195)	177 (237) 157 (210)	186 (250) 168 (225)	4400	49 (109)
MG-5011 IV*	PX-10290	3, 4, BW	1.14, 1.54, 2.06 2.51	164 (220) 145 (195)	177 (237) 157 (210)	186 (250) 168 (225)	4400	77 (170)
MG-5050 SC*	PX-12700	1, 2, 3, 4 SPEC. #3	1.00, 1.23, 1.53, 1.71, 2.04 2.45 3.00	226 (303) 226 (303) 200 (268)	245 (329) 233 (312) 213 (286)	272 (365) 261 (350) 231 (310)	3300	86 (189)
MG-5050 A*	PX-12730	1, 2, 3, 4 SPEC. #3	1.12, 1.26, 1.50, 1.80, 2.04 2.50	226 (303) 200 (268)	245 (329) 219 (294)	272 (365) 239 (320)	3300	80 (176)
MG-5050 RV*	PX-8760	—	1.12, 1.26, 1.50, 1.80, 2.04 2.50	226 (303) 200 (268)	245 (329) 219 (294)	272 (365) 239 (320)	3300	73 (160)
MG-5061 SC*	PX-11650/A	1, 2, 3 SPEC. #3	1.15, 1.48, 1.77, 2.00 2.43 3.00	283 (380) 263 (353) 245 (329)	308 (413) 286 (384) 266 (357)	354 (463) 321 (430) 298 (400)	3300	98 (215)
MG-5061 A*	PX-11640/A	1, 2, 3 SPEC. #3	1.13, 1.28, 1.54, 1.75, 2.00 2.47	283 (380) 263 (353)	308 (413) 286 (384)	354 (463) 321 (430)	3300	95 (210)
MG-5061 V*	PX-8735	—	1.13, 1.28, 1.54, 1.75, 2.00 2.47	283 (380) 263 (353)	308 (413) 286 (384)	354 (463) 321 (430)	3300	86 (190)
MG-5062 V*	PX-11660/A	1, 2, 3 SPEC. #3	1.19, 1.53, 1.83 2.07, 2.51	283 (380) 263 (353)	313 (420) 286 (384)	354 (475) 321 (430)	3300	142 (312)
MGX-5065 SC	PX-12410	1, 2, 3 SPEC. #3	1.08, 1.26, 1.47, 1.72, 2.04 2.43	393 (527) 368 (493)	425 (570) 400 (536)	474 (636) 448 (601)	3200	111 (244)
MGX-5065 A	PX-12370	1, 2, 3 SPEC. #3	1.08, 1.26, 1.47, 1.72, 2.04 2.43	393 (527) 368 (493)	425 (570) 400 (536)	474 (636) 448 (601)	3200	111 (244)
MG-5065 SC	PX-11480	1, 2, 3 SPEC. #3	1.08, 1.26, 1.47, 1.72, 2.04 2.43	393 (527) 368 (493)	425 (570) 400 (536)	474 (636) 448 (601)	3200	111 (244)
MG-5065 A	PX-11165	1, 2, 3 SPEC. #3	1.08, 1.26, 1.47, 1.72, 2.04 2.43	393 (527) 368 (493)	425 (570) 400 (536)	474 (636) 448 (601)	3200	111 (244)

Important — See rating definitions, application information, and torsional compatibility notices on pages 19 and 20.
 Ratings shown are in SAE Horsepower (HP). Metric Horsepower equals SAE times 1.014.
 Weights are approximate and include flywheel housing adapter and flexible input coupling.

* Consult Twin Disc for gasoline engine ratings.

**PLEASURE CRAFT RATINGS FOR STANDARD &
QUICKSHIFT® MARINE TRANSMISSIONS (Continued)**



Model	Drawing Number	SAE Housing	Ratios	KILOWATTS (HORSEPOWER)			Maximum Speed (rpm)	Dry Weight (kg (lb))
				@ 2300 RPM	@ 2500 RPM	@ 2800 RPM		
MGX-5075 SC	PX-12620	1, 2, 3 SPEC. #3	1.06, 1.22, 1.33, 1.53, 1.77, 2.05 2.53 2.88	423 (567) 380 (510) 373 (500)	455 (610) 410 (550) 403 (540)	503 (675) 453 (607) 434 (582)	3500	122 (268)
MGX-5075 A	PX-12610	1, 2, 3 SPEC. #3	1.06, 1.22, 1.33, 1.53, 1.77, 2.05 2.53 2.88	423 (567) 380 (510) 373 (500)	455 (610) 410 (550) 403 (540)	503 (675) 453 (607) 434 (582)	3500	122 (268)
MGX-5075 IV	PX-12630	1, 2, 3 SPEC. #3	1.03, 1.30, 1.49, 1.72, 1.99, 2.46	392 (526)	423 (567)	468 (628)	3500	150 (330)
MG-5075 SC	PX-11876	1, 2, 3 SPEC. #3	0.80, 0.92, 1.01, 1.16	380 (510)	410 (550)	453 (607)	3000	122 (268)
MG-5075 SC	PX-10680/A	1, 2, 3 SPEC. #3	1.06, 1.22, 1.33, 1.53, 1.77, 2.05 2.53 2.88	423 (567) 380 (510) 373 (500)	455 (610) 410 (550) 403 (540)	503 (675) 453 (607) 434 (582)	3500	122 (268)
MG-5075 A	PX-10700/A	1, 2, 3 SPEC. #3	1.06, 1.22, 1.33, 1.53, 1.77, 2.05 2.53 2.88	423 (567) 380 (510) 373 (500)	455 (610) 410 (550) 403 (540)	503 (675) 453 (607) 434 (582)	3500	122 (268)
MG-5075 IV	PX-11530-A	1, 2, 3 SPEC. #3	1.03, 1.30, 1.49, 1.72, 1.99, 2.46	392 (526)	423 (567)	468 (628)	3500	150 (330)
				@ 2100 RPM	@ 2300 RPM	@ 2500 RPM		
MG-5085 SC	PX-9260-B/C	1, 2, 3 SPEC. #3	1.05, 1.22, 1.42, 1.76 1.96 2.33	416 (558) 374 (502) 343 (460)	433 (580) 410 (550) 365 (490)	459 (615) 445 (597) 388 (520)	3200	120 (265)
MG-5085 A	PX-9360-B/C	1, 2, 3 SPEC. #3	1.05, 1.22, 1.47, 1.72 2.04 2.43	416 (558) 374 (502) 343 (460)	433 (580) 410 (550) 365 (490)	459 (615) 445 (597) 388 (520)	3200	123 (270)
MG-5082 SC	PX-11250-A	1, 2	1.06, 1.33, 1.53, 1.77, 2.05 2.53 2.88	490 (657) 462 (620) 428 (574)	522 (700) 492 (660) 447 (600)	543 (728) 521 (699) 465 (624)	3200	135 (298)
MG-5082 A	PX-11040-B	1, 2	1.06, 1.33, 1.53, 1.77, 2.05 2.53 2.88	490 (657) 462 (620) 428 (574)	530 (710) 492 (660) 447 (600)	543 (728) 521 (699) 465 (624)	3200	135 (298)
MGX-5086 SC	PX-12600	1, 2	1.06, 1.33, 1.53, 1.77, 2.05 2.53 2.88	490 (657) 462 (620) 428 (574)	522 (700) 492 (660) 447 (600)	543 (728) 521 (699) 465 (624)	3200	135 (298)
MGX-5086 A	PX-12290	1, 2	1.06, 1.33, 1.53, 1.77, 2.05 2.53 2.88	490 (657) 462 (620) 428 (574)	530 (710) 492 (660) 447 (600)	543 (728) 521 (699) 465 (624)	3200	135 (298)
MG-5091 SC	PX-10016	1, 2	1.17, 1.45, 1.71, 2.04 2.45 2.95	480 (643) 433 (580) 409 (548)	522 (700) 474 (635) 447 (600)	539 (723) 500 (670) 470 (630)	3000	220 (485)
MG-5090 A	PX-10015	1, 2	1.45, 1.73, 1.96 2.43	484 (649) 433 (580)	530 (710) 474 (635)	539 (723) 500 (670)	3000	216 (475)
MGX-5095 SC	PX-12480	1, 2	1.15, 1.27, 1.47, 1.71, 2.00, 2.46 2.95	544 (730) 510 (684)	597 (800) 560 (751)	634 (850) 608 (815)	3000	190 (419)
MGX-5095 A	PX-12360	1, 2	1.28, 1.52, 1.81, 2.04 2.48	560 (751) 521 (699)	597 (800) 560 (751)	634 (850) 599 (803)	3000	185 (407)
MGX-5095 RV	PX-12550	—	1.28, 1.52, 1.81, 2.04 2.48	560 (751) 521 (699)	597 (800) 560 (751)	634 (850) 599 (803)	3000	178 (392)
MG-5095 SC	PX-11535	1, 2	1.15, 1.27, 1.47, 1.71, 2.00, 2.46 2.95	544 (730) 510 (684)	597 (800) 560 (751)	634 (850) 608 (815)	3000	190 (419)
MG-5095 A	PX-11495	1, 2	1.28, 1.52, 1.81, 2.04 2.48	560 (751) 521 (699)	597 (800) 560 (751)	634 (850) 599 (803)	3000	185 (407)
MG-5095 RV	PX-11600	—	1.28, 1.52, 1.81, 2.04 2.48	560 (751) 521 (699)	597 (800) 560 (751)	634 (850) 599 (803)	3000	178 (392)

Important — See rating definitions, application information, and torsional compatibility notices on pages 19 and 20.
Ratings shown are in SAE Horsepower (HP). Metric Horsepower equals SAE times 1.014.
Weights are approximate and include flywheel housing adapter and flexible input coupling.

PLEASURE CRAFT RATINGS FOR STANDARD & QUICKSHIFT® MARINE TRANSMISSIONS (Continued)



Model	Drawing Number	SAE Housing	Ratios	KILOWATTS (HORSEPOWER)			Maximum Speed (rpm)	Dry Weight (kg (lb))
				@ 2100 RPM	@ 2300 RPM	@ 2500 RPM		
MGX-5114 SC	PX-12490	1	0.93, 1.02, 1.12, 1.50, 1.74, 2.04, 2.54 3.00	619 (830) 528 (708)	673 (900) 578 (775)	716 (960) 629 (843)	2800 for 0.93:1 3000 for others	203 (447)
MGX-5114 SC-HD	PX-12860	1	1.50, 1.74, 2.04, 2.54 3.00	619 (830) 528 (708)	673 (900) 578 (775)	716 (960) 629 (843)	3000	270 (595)
MGX-5114 DC	PX-12170	1	3.28, 3.43, 4.17 4.59 4.86	619 (830) 579 (776) 567 (760)	673 (900) 634 (850) 604 (810)	701 (940) 679 (911) 634 (850)	3000	360 (793)
MGX-5114 A	1024390	1, 2	1.03, 1.20, 1.48, 1.75, 1.92 2.04, 2.50	619 (830)	673 (900)	701 (940)	3000	206 (455)
MGX-5114 RV	PX-11850	—	1.03, 1.20, 1.48, 1.75, 1.92 2.04, 2.50	619 (830)	673 (900)	701 (940)	3000	198 (435)
MGX-5114 IV	PX-12510	1, 2	1.05, 1.23, 1.52, 1.80, 1.97 2.57	619 (830) 599 (803)	673 (900) 649 (870)	701 (940) 677 (908)	3000	270 (595)
MG-5114 SC	PX-9785-B	1	0.93, 1.02, 1.12, 1.50, 1.74, 2.04, 2.54 3.00	619 (830) 528 (708)	673 (900) 578 (775)	716 (960) 629 (843)	2800 for 0.93:1 3000 for others	203 (447)
MG-5114 DC	PX-10250-A PX-12195(FS)	1 Ind.	3.28, 3.43, 4.17 4.59 4.86	619 (830) 579 (776) 567 (760)	673 (900) 634 (850) 604 (810)	701 (940) 679 (911) 634 (850)	3000	368 (810)
MG-5114 A	PX-11915	1, 2	1.03, 1.20, 1.48, 1.75, 1.92 2.04, 2.50	619 (830)	673 (900)	701 (940)	3000	206 (455)
MG-5114 RV	PX-9830-A	—	1.03, 1.20, 1.48, 1.75, 1.92 2.04, 2.50	619 (830)	673 (900)	701 (940)	3000	198 (435)
MG-5114 IV	PX-11920	1, 2	1.05, 1.23, 1.52, 1.80, 1.97 2.57	619 (830) 599 (803)	673 (900) 649 (870)	701 (940) 677 (908)	3000	270 (595)
				@ 2100 RPM	@ 2300 RPM	@ 2450 RPM		
MGX-5135 SC	PX-12450	1, 0	1.10, 1.28, 1.48, 1.73, 2.04 2.57 2.90	817 (1096) 734 (984) 668 (896)	895 (1200) 820 (1100) 746 (1000)	954 (1279) 873 (1170) 794 (1065)	2800	284 (625)
MGX-5135 A	PX-12380	1, 0	1.16, 1.25, 1.53, 1.79, 2.00 2.52	817 (1096) 734 (984)	895 (1200) 820 (1100)	954 (1279) 873 (1170)	2800	280 (617)
MGX-5135 RV	PX-12520	—	1.16, 1.25, 1.53, 1.79, 2.00 2.52	817 (1096) 734 (984)	895 (1200) 820 (1100)	954 (1279) 873 (1170)	2800	258 (568)
MG-5135 SC	PX-11590	1, 0	1.10, 1.28, 1.48, 1.73, 2.04 2.57 2.90	817 (1096) 734 (984) 668 (896)	895 (1200) 820 (1100) 746 (1000)	954 (1279) 873 (1170) 794 (1065)	2800	284 (625)
MG-5135 A	PX-11380	1, 0	1.16, 1.25, 1.53, 1.79, 2.00 2.52	817 (1096) 734 (984)	895 (1200) 820 (1100)	954 (1279) 873 (1170)	2800	280 (617)
MG-5135 RV	PX-11945	—	1.16, 1.25, 1.53, 1.79, 2.00 2.52	817 (1096) 734 (984)	895 (1200) 820 (1100)	954 (1279) 873 (1170)	2800	258 (568)
MGX-5145 SC	PX-12460	1, 0	1.03, 1.20, 1.33, 1.48, 1.75, 1.96 2.50	949 (1273) 841 (1128)	1007 (1350) 916 (1228)	1050 (1408) 963 (1291)	2500	325 (716)
MGX-5145 A	PX-12420	1, 0	1.26, 1.48, 1.75, 1.96 2.50	949 (1273) 878 (1177)	1007 (1350) 956 (1282)	1050 (1408) 1004 (1346)	2500	333 (734)
MGX-5145 RV	PX-12530	—	1.26, 1.48, 1.75, 1.96 2.50	949 (1273) 878 (1177)	1007 (1350) 956 (1282)	1050 (1408) 1004 (1346)	2500	295 (650)
MG-5145 SC	PX-10885	1, 0	1.03, 1.20, 1.33, 1.48, 1.75, 1.96 2.50	949 (1273) 841 (1128)	1007 (1350) 916 (1228)	1050 (1408) 963 (1291)	2500	325 (716)
MG-5145 A	PX-10830	1, 0	1.26, 1.48, 1.75, 1.96 2.50	949 (1273) 878 (1177)	1007 (1350) 956 (1282)	1050 (1408) 1004 (1346)	2500	333 (734)
MG-5145 RV	PX-10880	—	1.26, 1.48, 1.75, 1.96 2.50	949 (1273) 878 (1177)	1007 (1350) 956 (1282)	1050 (1408) 1004 (1346)	2500	295 (650)

Important — See rating definitions, application information, and torsional compatibility notices on pages 19 and 20.
 Ratings shown are in SAE Horsepower (HP). Metric Horsepower equals SAE times 1.014.
 Weights are approximate and include flywheel housing adapter and flexible input coupling.

**PLEASURE CRAFT RATINGS FOR STANDARD &
QUICKSHIFT® MARINE TRANSMISSIONS (Continued)**



Model	Drawing Number	SAE Housing	Ratios	KILOWATTS (HORSEPOWER)			Maximum Speed (rpm)	Dry Weight (kg (lb))
				@ 2100 RPM	@ 2300 RPM	@ 2450 RPM		
<u>MGX-5147 SC</u>	PX-12470-A	1, 0	1.20, 1.33, 1.48, 1.57, 1.75, 1.96 2.50	1070 (1435) 875 (1173)	1142 (1531) 952 (1277)	1195 (1603) 1001 (1342)	2500	325 (716)
<u>MGX-5147 A</u>	PX-12430-A	1, 0	1.26, 1.48, 1.75, 1.96 2.50	1070 (1435) 931 (1248)	1142 (1531) 1014 (1360)	1195 (1603) 1065 (1428)	2500	333 (734)
<u>MGX-5147 RV</u>	PX-12540-A	—	1.26, 1.48, 1.75, 1.96 2.50	1070 (1435) 931 (1248)	1142 (1531) 1014 (1360)	1195 (1603) 1065 (1428)	2500	295 (650)
<u>MG-5202 SC</u>	1016103-C	1, 0 Ind.	1.17, 1.33, 1.53, 1.76, 2.03, 2.48, 2.92 3.48	886 (1188) 742 (995)	969 (1300) 800 (1073)	1019 (1366) 841 (1128)	2750 (2500 at 1.17:1)	587 (1292)
<u>MG-5203 SC</u>	1016249-A	1, 0 Ind.	1.17, 1.33, 1.53, 1.76, 2.03, 2.48, 2.92 3.48	886 (1188) 742 (995)	969 (1300) 800 (1073)	1019 (1366) 841 (1128)	2750 (2500 at 1.17:1)	409 (900)
<u>MG-5204 SC</u>	1016250-B	1, 0 Ind.	1.17, 1.33, 1.53, 1.76, 2.03, 2.48, 2.92 3.48	1029 (1380) 984 (1320)	1104 (1480) 1081 (1450)	1104 (1480) 1081 (1450)	2750 (2500 at 1.17:1)	409 (900)
<u>MG-6449 A</u>	7-37423	1, 0 Ind.	1.51, 1.73, 2.07, 2.44 2.95	1007 (1350) 715 (959)	1104 (1480) 782 (1050)	1104 (1480) 782 (1050)	2500	344 (757)
<u>MG-6449 RV</u>	7-37431-A	—	1.51, 1.73, 2.07, 2.44 2.95	1007 (1350) 715 (959)	1104 (1480) 782 (1050)	1104 (1480) 782 (1050)	2500	325 (716)
<u>MGX-6598 DC</u>	7-40379	1, 0 Ind.	2.46, 3.03, 3.48 3.93 4.43	1335 (1790) 1226 (1644) 1070 (1435)	1462 (1961) 1343 (1801) 1172 (1572)	1557 (2088) 1399 (1876) 1249 (1674)	2500	580 (1278)
<u>MGX-6599 SC</u>	7-40384	1, 0 Ind.	1.07, 1.30, 1.50, 1.66 1.74, 1.97, 2.04, 2.19 2.45 2.82	1326 (1778) 1295 (1737) 1226 (1644) 1056 (1416)	1452 (1947) 1418 (1902) 1343 (1801) 1156 (1550)	1518 (2036) 1510 (2024) 1431 (1919) 1232 (1652)	2500	492 (1084)
<u>MGX-6599 A</u>	7-40263	1, 0 Ind.	1.34, 1.51, 1.74, 2.03, 2.24 2.48 2.80	1295 (1737) 1226 (1644) 1056 (1416)	1418 (1902) 1343 (1801) 1156 (1550)	1510 (2024) 1431 (1919) 1232 (1652)	2500	488 (1075)
<u>MGX-6599 RV</u>	7-40336	—	1.34, 1.51, 1.74, 2.03, 2.24 2.48 2.80	1295 (1737) 1226 (1644) 1056 (1416)	1418 (1902) 1343 (1801) 1156 (1550)	1510 (2024) 1431 (1919) 1232 (1652)	2500	468 (1031)
<u>MG-6600 DC</u>	7-36712-A	0 Ind.	3.30, 4.11 4.68, 4.72 5.21 6.05	1319 (1769) 1225 (1643) 1103 (1479) 987 (1324)	1445 (1938) 1342 (1800) 1208 (1620) 1081 (1450)	1539 (2064) 1430 (1918) 1287 (1726) 1152 (1545)	2500	794 (1747)
<u>MGX-6620 SC</u>	7-40337	0 Ind.	1.15, 1.33, 1.53, 1.73 2.03, 2.32, 2.44 2.72	1430 (1918) 1430 (1918) 1342 (1800)	1566 (2100) 1566 (2100) 1470 (1971)	1668 (2237) 1668 (2237) 1556 (2087)	2500	575 (1267)
<u>MGX-6620 A</u>	7-40264	0 Ind.	1.55, 1.72, 2.09, 2.28, 2.42 2.73	1430 (1918) 1373 (1841)	1566 (2100) 1504 (2017)	1668 (2237) 1602 (2148)	2500	580 (1278)
<u>MGX-6620 RV</u>	7-40316	—	1.55, 1.72, 2.09, 2.28, 2.42 2.73	1430 (1918) 1373 (1841)	1566 (2100) 1504 (2017)	1668 (2237) 1602 (2148)	2500	510 (1123)
<u>MGX-6650 SC</u>	1002046	0, 00 Ind.	1.51, 1.88, 2.03, 2.37 2.47, 2.81, 2.93, 3.21	1430 (1918)	1566 (2100)	1602 (2148)	2300 (1.51–2.37) 2500 (2.47–3.21)	1001 (2205)
<u>MGX-6690 SC</u>	1020674	0, 00 Ind.	1.51, 1.88, 2.03, 2.37 2.47, 2.81, 2.93, 3.21	1534 (2057)	1680 (2253)	1790 (2400)	2300 (1.51–2.37) 2500 (2.47–3.21)	1001 (2205)
<u>MGX-6848 SC</u>	1020675	0, 00	1.51, 1.88, 2.03, 2.37 2.47 2.58, 2.93 3.21	1864 (2500) 1864 (2500) 1891 (2536) 1526 (2046)	2028 (2720) 2028 (2720) 1891 (2536) 1653 (2217)	— 2147 (2879) 2001 (2682) 1748 (2343)	2300 (1.51–2.37) 2500 (2.47–3.21)	1001 (2205)

Important — See rating definitions, application information, and torsional compatibility notices on pages 19 and 20.
Ratings shown are in SAE Horsepower (HP). Metric Horsepower equals SAE times 1.014.
Weights are approximate and include flywheel housing adapter and flexible input coupling.

**PLEASURE CRAFT RATINGS FOR STANDARD &
QUICKSHIFT® MARINE TRANSMISSIONS (Continued)**



Model	Drawing Number	SAE Housing	Ratios	KILOWATTS (HORSEPOWER)			Maximum Speed (rpm)	Dry Weight (kg (lb))
				@ 1600 RPM	@ 1800 RPM	@ 2100 RPM		
MG-6984 SC	7-37008	Ind. 0 00	1.18, 1.54, 2.06, 2.29, 2.52 2.92 3.25 3.43	1693 (2270)	1905 (2555)	2222 (2980)	2100	1192 (2628)
	7-37481			1648 (2210)	1854 (2486)	2163 (2900)		
	P-71034-B			1466 (1966)	1649 (2211)	1924 (2580)		
				1364 (1829)	1534 (2057)	1790 (2400)		
MG-6984 A	7-37028	Ind. 0 00	1.48, 1.97, 2.50 2.79 2.93	1693 (2270)	1905 (2555)	2222 (2980)	2100	909 (2000)
	P-71093			1682 (2256)	1892 (2537)	2207 (2960)		
	P-71094			1642 (2202)	1847 (2477)	2155 (2890)		
MG-6984 RV	7-37042	—	1.48, 1.97, 2.50 2.79 2.93	1693 (2270)	1905 (2555)	2222 (2980)	2100	909 (2000)
				1682 (2256)	1892 (2537)	2207 (2960)		
				1642 (2202)	1847 (2477)	2155 (2890)		
MG-61242 SC	7-37017	Ind.	1.16, 1.52, 2.08, 2.47 2.96	2176 (2918)	2448 (3283)	2856 (3830)	2100	1050 (2310)
				2091 (2804)	2353 (3155)	2745 (3681)		
MG-61242 A	7-37046	Ind.	1.42, 2.07, 2.44 2.93	2176 (2918)	2448 (3283)	2856 (3830)	2100	1105 (2431)
				2074 (2781)	2333 (3129)	2722 (3650)		
MG-61242 RV	7-37049	—	1.42, 2.07, 2.44 2.93	2176 (2918)	2448 (3283)	2856 (3830)	2100	1105 (2431)
				2074 (2781)	2333 (3129)	2722 (3650)		

Important — See rating definitions, application information, and torsional compatibility notices on pages 19 and 20.
Ratings shown are in SAE Horsepower (HP). Metric Horsepower equals SAE times 1.014.
Weights are approximate and include flywheel housing adapter and flexible input coupling.

LIGHT DUTY RATINGS FOR STANDARD & QUICKSHIFT® MARINE TRANSMISSIONS



Model	Drawing Number	SAE Housing	Ratios	KILOWATTS (HORSEPOWER)			Maximum Speed (rpm)	Dry Weight (kg (lb))
				@ 2300 RPM	@ 2500 RPM	@ 2800 RPM		
MG-5011 SC*	PX-10270	3, 4, BW	1.11, 1.27, 1.50, 2.00 2.44	153 (205) 136 (182)	165 (221) 146 (196)	174 (233) 157 (211)	4400	49 (109)
MG-5011 A*	PX-9999	3, 4, BW	1.44, 1.90 2.39	153 (205) 136 (182)	165 (221) 146 (196)	174 (233) 157 (211)	4400	49 (109)
MG-5011 IV*	PX-10290	3, 4, BW	1.14, 1.54, 2.06 2.51	153 (205) 136 (182)	165 (221) 146 (196)	174 (233) 157 (211)	4400	77 (170)
MG-5050 SC*	PX-12700	1, 2, 3, 4 SPEC. #3	1.00, 1.23, 1.53, 1.71, 2.04 2.45 3.00	211 (283) 211 (283) 187 (251)	228 (306) 216 (290) 198 (266)	254 (341) 223 (299) 216 (290)	3300	86 (189)
MG-5050 A*	PX-12730	1, 2, 3, 4 SPEC. #3	1.12, 1.26, 1.50, 1.80, 2.04 2.50	211 (283) 187 (251)	228 (306) 204 (274)	254 (341) 223 (299)	3300	80 (176)
MG-5050 RV*	PX-8760	—	1.12, 1.26, 1.50, 1.80, 2.04 2.50	211 (283) 187 (251)	228 (306) 204 (274)	254 (341) 223 (299)	3300	73 (160)
MG-5061 SC*	PX-11650/A	1, 2, 3 SPEC. #3	1.15, 1.48, 1.77, 2.00 2.43 3.00	265 (355) 246 (330) 229 (307)	288 (386) 268 (360) 248 (333)	323 (433) 300 (402) 279 (374)	3300	98 (215)
MG-5061 A*	PX-11640/A	1, 2, 3 SPEC. #3	1.13, 1.28, 1.54, 1.75 2.00, 2.47	257 (345) 246 (330)	281 (377) 268 (360)	313 (420) 300 (402)	3300	95 (210)
MG-5061 V*	PX-8735	—	1.13, 1.28, 1.54, 1.75 2.00, 2.47	257 (345) 246 (330)	281 (377) 268 (360)	313 (420) 300 (402)	3300	86 (190)
MG-5062 V*	PX-11660/A	1, 2, 3 SPEC. #3	1.19, 1.53, 1.83 2.07, 2.51	265 (355) 246 (330)	292 (392) 268 (360)	331 (444) 300 (402)	3300	142 (312)
MGX-5065 SC	PX-12410	1, 2, 3 SPEC. #3	1.08, 1.26, 1.47, 1.72, 2.04 2.43	376 (504) 351 (471)	407 (546) 381 (511)	453 (607) 428 (574)	3200	111 (244)
MGX-5065 A	PX-12370	1, 2, 3 SPEC. #3	1.08, 1.26, 1.47, 1.72, 2.04 2.43	376 (504) 351 (471)	407 (546) 381 (511)	453 (607) 428 (574)	3200	111 (244)
MG-5065 SC	PX-11480	1, 2, 3 SPEC. #3	1.08, 1.26, 1.47, 1.72, 2.04 2.43	376 (504) 351 (471)	407 (546) 381 (511)	453 (607) 428 (574)	3200	111 (244)
MG-5065 A	PX-11165	1, 2, 3 SPEC. #3	1.08, 1.26, 1.47, 1.72, 2.04 2.43	376 (504) 351 (471)	407 (546) 381 (511)	453 (607) 428 (574)	3200	111 (244)
MGX-5075 SC	PX-12620	1, 2, 3 SPEC. #3	1.06, 1.22, 1.33, 1.53, 1.77, 2.05 2.53 2.88	368 (493) 355 (476) 348 (467)	390 (523) 383 (514) 375 (503)	433 (581) 423 (567) 406 (544)	3500	122 (268)
MGX-5075 A	PX-12610	1, 2, 3 SPEC. #3	1.06, 1.22, 1.33, 1.53, 1.77, 2.05 2.53 2.88	368 (493) 355 (476) 348 (467)	390 (523) 383 (514) 375 (503)	433 (581) 423 (567) 406 (544)	3500	122 (268)
MGX-5075 IV	PX-12630	1, 2, 3 SPEC. #3	1.03, 1.30, 1.49, 1.72, 1.99, 2.46	355 (476)	383 (514)	423 (567)	3500	150 (330)
MG-5075 SC	PX-11876	1, 2, 3 SPEC. #3	0.80, 0.92, 1.01, 1.16	355 (476)	383 (514)	423 (567)	3000	122 (268)
MG-5075 SC	PX-10680/A	1, 2, 3 SPEC. #3	1.06, 1.22, 1.33, 1.53, 1.77, 2.05 2.53 2.88	368 (493) 355 (476) 348 (467)	390 (523) 383 (514) 375 (503)	433 (581) 423 (567) 406 (544)	3500	122 (268)
MG-5075 A	PX-10700/A	1, 2, 3 SPEC. #3	1.06, 1.22, 1.33, 1.53, 1.77, 2.05 2.53 2.88	368 (493) 355 (476) 348 (467)	390 (523) 383 (514) 375 (503)	433 (581) 423 (567) 406 (544)	3500	122 (268)
MG-5075 IV	PX-11530	1, 2, 3 SPEC. #3	1.03, 1.30, 1.49, 1.72, 1.99, 2.46	355 (476)	383 (514)	423 (567)	3500	150 (330)
				@ 2100 RPM	@ 2300 RPM	@ 2500 RPM		
MG-5085 SC	PX-9260-B/C	1, 2, 3 SPEC. #3	1.05, 1.22, 1.42, 1.76 1.96 2.33	389 (522) 348 (467) 321 (430)	404 (542) 383 (514) 342 (459)	429 (575) 416 (558) 362 (485)	3200	120 (265)
MG-5085 A	PX-9360-B/C	1, 2, 3 SPEC. #3	1.05, 1.22, 1.47, 1.72 2.04 2.43	389 (522) 355 (476) 321 (430)	404 (542) 383 (514) 342 (459)	429 (575) 416 (558) 362 (485)	3200	123 (270)

Important — See rating definitions, application information, and torsional compatibility notices on pages 19 and 20.
 Ratings shown are in SAE Horsepower (HP). Metric Horsepower equals SAE times 1.014.
 Weights are approximate and include flywheel housing adapter and flexible input coupling.

* Consult Twin Disc for gasoline engine ratings.

LIGHT DUTY RATINGS FOR STANDARD & QUICKSHIFT® MARINE TRANSMISSIONS (Continued)



Model	Drawing Number	SAE Housing	Ratios	KILOWATTS (HORSEPOWER)			Maximum Speed (rpm)	Dry Weight (kg (lb))
				@ 2100 RPM	@ 2300 RPM	@ 2500 RPM		
MG-5082 SC	PX-11250-A	1, 2	1.06, 1.33, 1.53, 1.77, 2.05, 2.53 2.88	432 (579) 400 (536)	460 (617) 418 (560)	487 (653) 434 (582)	3200	135 (298)
MG-5082 A	PX-11040-B	1, 2	1.06, 1.33, 1.53, 1.77, 2.05, 2.53 2.88	432 (579) 400 (536)	460 (617) 418 (560)	487 (653) 434 (582)	3200	135 (298)
MGX-5086 SC	PX-12600	1, 2	1.06, 1.33, 1.53, 1.77, 2.05, 2.53 2.88	432 (579) 400 (536)	460 (617) 418 (560)	487 (653) 434 (582)	3200	135 (298)
MGX-5086 A	PX-12290	1, 2	1.06, 1.33, 1.53, 1.77, 2.05, 2.53 2.88	432 (579) 400 (536)	460 (617) 418 (560)	487 (653) 434 (582)	3200	135 (298)
MG-5091 SC	PX-10016	1, 2	1.17, 1.45, 1.71, 2.04 2.45 2.95	429 (575) 404 (542) 382 (512)	471 (632) 442 (593) 418 (561)	495 (664) 467 (626) 439 (589)	3000	220 (485)
MG-5090 A	PX-10015	1, 2	1.45, 1.73, 1.96 2.43	429 (575) 404 (542)	471 (632) 442 (593)	494 (662) 434 (626)	3000	216 (475)
MGX-5095 SC	PX-12480	1, 2	1.15, 1.27, 1.47, 1.71, 2.00, 2.46 2.95	525 (704) 481 (645)	560 (751) 522 (700)	593 (795) 554 (743)	3000	190 (419)
MGX-5095 A	PX-12360	1, 2	1.28, 1.52, 1.81, 2.04 2.48	525 (704) 485 (650)	560 (751) 522 (700)	594 (797) 558 (748)	3000	185 (407)
MGX-5095 RV	PX-12550	—	1.28, 1.52, 1.81, 2.04 2.48	525 (704) 485 (650)	560 (751) 522 (700)	594 (797) 558 (748)	3000	178 (392)
MG-5095 SC	PX-11535	1, 2	1.15, 1.27, 1.47, 1.71, 2.00, 2.46 2.95	525 (704) 481 (645)	560 (751) 522 (700)	593 (795) 554 (743)	3000	190 (419)
MG-5095 A	PX-11495	1, 2	1.28, 1.52, 1.81, 2.04 2.48	525 (704) 485 (650)	560 (751) 522 (700)	594 (797) 558 (748)	3000	185 (407)
MG-5095 RV	PX-11600	—	1.28, 1.52, 1.81, 2.04 2.48	525 (704) 485 (650)	560 (751) 522 (700)	594 (797) 558 (748)	3000	178 (392)
MGX-5114 SC	PX-12490	1	0.93, 1.02, 1.12, 1.50, 1.74 2.04, 2.54 3.00	579 (776) 579 (776) 494 (662)	629 (843) 629 (843) 540 (724)	669 (897) 669 (897) 588 (789)	2800 at .93:1 3000 for others	203 (447)
MGX-5114 SC-HD	PX-12860	1	1.50, 1.74, 2.04, 2.54 3.00	579 (776) 494 (662)	629 (843) 540 (724)	669 (897) 588 (789)	3000	270 (595)
MGX-5114 DC	PX-12170	1	3.28, 3.43, 4.17 4.59 4.86	580 (777) 541 (725) 530 (711)	629 (843) 629 (843) 540 (724)	655 (878) 634 (850) 576 (772)	3000	360 (793)
MGX-5114 A	1024390	1, 2	1.03, 1.20, 1.48, 1.75, 1.92 2.04, 2.50	580 (777)	629 (843)	655 (878)	3000	206 (455)
MGX-5114 RV	PX-11850	—	1.03, 1.20, 1.48, 1.75, 1.92 2.04, 2.50	580 (777)	629 (843)	655 (878)	3000	198 (435)
MGX-5114 IV	PX-12510	1, 2	1.05, 1.23, 1.52, 1.80, 1.97 2.57	580 (777) 560 (751)	629 (843) 607 (814)	655 (878) 632 (848)	3000	270 (595)
MG-5114 SC	PX-9785-B	1	0.93, 1.02, 1.12, 1.50, 1.74, 2.04, 2.54 3.00	579 (776) 494 (662)	629 (843) 540 (724)	669 (897) 588 (789)	2800 at .93:1 3000 for others	203 (447)
MG-5114 DC	PX-10250-A PX-12195(FS)	1 Ind.	3.28, 3.43, 4.17 4.59 4.86	579 (776) 542 (727) 530 (711)	629 (843) 591 (793) 565 (758)	656 (880) 634 (850) 575 (771)	3000	368 (810)
MG-5114 A	PX-11915	1, 2	1.03, 1.20, 1.48, 1.75, 1.92 2.04, 2.50	580 (777)	629 (843)	656 (880)	3000	206 (455)
MG-5114 RV	PX-9830-A	—	1.03, 1.20, 1.48, 1.75, 1.92 2.04, 2.50	580 (777)	629 (843)	656 (880)	3000	198 (435)
MG-5114 IV	PX-11920	1, 2	1.05, 1.23, 1.52, 1.80, 1.97 2.57	580 (777) 560 (751)	629 (843) 607 (814)	656 (880) 632 (848)	3000	270 (595)

Important — See rating definitions, application information, and torsional compatibility notices on pages 19 and 20.
Ratings shown are in SAE Horsepower (HP). Metric Horsepower equals SAE times 1.014.
Weights are approximate and include flywheel housing adapter and flexible input coupling.

LIGHT DUTY RATINGS FOR STANDARD & QUICKSHIFT® MARINE TRANSMISSIONS (Continued)



Model	Drawing Number	SAE Housing	Ratios	KILOWATTS (HORSEPOWER)			Maximum Speed (rpm)	Dry Weight (kg (lb))
				@ 2100 RPM	@ 2300 RPM	@ 2500 RPM		
MGX-5135 SC	PX-12450	1, 0	1.10, 1.28, 1.48, 1.73, 2.04 2.57 2.90	704 (944) 663 (889) 622 (834)	746 (1000) 716 (960) 671 (900)	788 (1057) 768 (1030) 720 (966)	2800	284 (625)
MGX-5135 A	PX-12380	1, 0	1.16, 1.25, 1.53, 1.79, 2.00 2.52	704 (944) 663 (889)	746 (1000) 716 (960)	788 (1057) 768 (1030)	2800	280 (617)
MGX-5135 RV	PX-12520	—	1.16, 1.25, 1.53, 1.79, 2.00 2.52	704 (944) 663 (889)	746 (1000) 716 (960)	788 (1057) 768 (1030)	2800	258 (568)
MG-5135 SC	PX-11590	1, 0	1.10, 1.28, 1.48, 1.73, 2.04 2.57 2.90	704 (944) 663 (889) 622 (834)	746 (1000) 716 (960) 671 (900)	788 (1057) 768 (1030) 720 (966)	2800	284 (625)
MG-5135 A	PX-11380	1, 0	1.16, 1.25, 1.53, 1.79, 2.00 2.52	704 (944) 663 (889)	746 (1000) 716 (960)	788 (1057) 768 (1030)	2800	280 (617)
MG-5135 RV	PX-11945	—	1.16, 1.25, 1.53, 1.79, 2.00 2.52	704 (944) 663 (889)	746 (1000) 716 (960)	788 (1057) 768 (1030)	2800	258 (568)
MGX-5145 SC	PX-12460	1, 0	1.03, 1.20, 1.33, 1.48, 1.75, 1.96 2.50	808 (1084) 759 (1018)	857 (1150) 820 (1100)	906 (1215) 881 (1181)	2500	325 (716)
MGX-5145 A	PX-12420	1, 0	1.26, 1.48, 1.75, 1.96 2.50	808 (1084) 759 (1018)	857 (1150) 820 (1100)	906 (1215) 881 (1181)	2500	333 (734)
MGX-5145 RV	PX-12530	—	1.26, 1.48, 1.75, 1.96 2.50	808 (1084) 759 (1018)	857 (1150) 820 (1100)	906 (1215) 881 (1181)	2500	295 (650)
MG-5145 SC	PX-10885	1, 0	1.03, 1.20, 1.33, 1.48, 1.75, 1.96 2.50	808 (1084) 759 (1018)	857 (1150) 820 (1100)	906 (1215) 881 (1181)	2500	325 (716)
MG-5145 A	PX-10830	1, 0	1.26, 1.48, 1.75, 1.96 2.50	808 (1084) 759 (1018)	857 (1150) 820 (1100)	906 (1215) 881 (1181)	2500	333 (734)
MG-5145 RV	PX-10880	—	1.26, 1.48, 1.75, 1.96 2.50	808 (1084) 759 (1018)	857 (1150) 820 (1100)	906 (1215) 881 (1181)	2500	295 (650)
MGX-5147 SC	PX-12470-A	1, 0	1.20, 1.33, 1.48, 1.57, 1.75, 1.96 2.50	918 (1231) 828 (1110)	974 (1306) 895 (1200)	1028 (1379) 961 (1289)	2500	325 (716)
MGX-5147 A	PX-12430-A	1, 0	1.26, 1.48, 1.75, 1.96 2.50	918 (1231) 828 (1110)	974 (1306) 895 (1200)	1028 (1379) 961 (1289)	2500	333 (734)
MGX-5147 RV	PX-12540-A	—	1.26, 1.48, 1.75, 1.96 2.50	918 (1231) 828 (1110)	974 (1306) 895 (1200)	1028 (1379) 961 (1289)	2500	295 (650)
				@ 1800 RPM	@ 2100 RPM	@ 2300 RPM		
MG-5202 SC	1016103-C	1, 0 Ind.	1.17, 1.33, 1.53, 1.76, 2.03, 2.48, 2.92 3.48	742 (995) 641 (860)	852 (1142) 731 (980)	924 (1239) 789 (1059)	2750	587 (1292)
MG-5203 SC	1016249-A	1, 0 Ind.	1.17, 1.33, 1.53, 1.76, 2.03, 2.48, 2.92 3.48	742 (995) 641 (860)	852 (1142) 731 (980)	924 (1239) 789 (1059)	2750	409 (900)
MG-5204 SC	1016250-B	1, 0 Ind.	1.17, 1.33, 1.53, 1.76, 2.03, 2.48, 2.92 3.48	742 (995) 647 (868)	865 (1160) 764 (1025)	979 (1313) 837 (1122)	2750	409 (900)
MG-6449 A	7-37423	1, 0 Ind.	1.51, 1.73 2.07 2.44 2.95	840 (1126) 795 (1067) 711 (953) 545 (731)	978 (1312) 912 (1223) 805 (1080) 635 (852)	1072 (1437) 974 (1306) 861 (1154) 696 (933)	2500	344 (757)
MG-6449 RV	7-37431-A	—	1.51, 1.73 2.07 2.44 2.95	840 (1126) 795 (1067) 711 (953) 545 (731)	978 (1312) 912 (1223) 805 (1080) 635 (852)	1072 (1437) 974 (1306) 861 (1154) 696 (933)	2500	325 (716)
MGX-6598 DC	7-40379	1, 0 Ind.	2.46, 3.03 3.48 3.93 4.43	1000 (1341) 1000 (1341) 952 (1277) 862 (1156)	1167 (1565) 1155 (1549) 1060 (1421) 990 (1328)	1278 (1714) 1241 (1664) 1131 (1517) 1055 (1415)	2500	580 (1278)
MGX-6599 SC	7-40384	1, 0 Ind.	1.07, 1.30, 1.50, 1.66, 1.74 1.97, 2.04, 2.19 2.45 2.82	1010 (1354) 1001 (1342) 920 (1234) 821 (1101)	1178 (1580) 1167 (1565) 1073 (1439) 955 (1281)	1244 (1668) 1234 (1655) 1164 (1561) 1042 (1397)	2500	492 (1084)

Important — See rating definitions, application information, and torsional compatibility notes on pages 19 and 20.
 Ratings shown are in SAE Horsepower (HP). Metric Horsepower equals SAE times 1.014.
 Weights are approximate and include flywheel housing adapter and flexible input coupling.

LIGHT DUTY RATINGS FOR STANDARD & QUICKSHIFT® MARINE TRANSMISSIONS (Continued)



Model	Drawing Number	SAE Housing	Ratios	KILOWATTS (HORSEPOWER)			Maximum Speed (rpm)	Dry Weight (kg (lb))
				@ 1800 RPM	@ 2100 RPM	@ 2300 RPM		
MGX-6599 A	7-40263	1, 0 Ind.	1.34, 1.51, 1.74, 2.03, 2.24 2.48 2.80	1092 (1464) 935 (1254) 896 (1202)	1221 (1637) 1091 (1463) 1045 (1401)	1301 (1745) 1195 (1602) 1144 (1534)	2500	488 (1075)
MGX-6599 RV	7-40336	—	1.34, 1.51, 1.74, 2.03, 2.24 2.48 2.80	1092 (1464) 935 (1254) 896 (1202)	1221 (1637) 1091 (1463) 1045 (1401)	1301 (1745) 1195 (1602) 1144 (1534)	2500	468 (1031)
MG-6600 DC	7-36712A	0 Ind.	3.30, 4.11 4.68, 4.72 5.22 6.05	1009 (1353) 926 (1242) 818 (1097) 722 (968)	1177 (1578) 1080 (1448) 953 (1278) 843 (1129)	1289 (1728) 1182 (1585) 1044 (1400) 923 (1237)	2500	794 (1747)
MGX-6620 SC	7-40337	0 Ind.	1.15 1.33, 1.53, 1.73, 2.03 2.32, 2.44 2.72	1109 (1487) 1109 (1487) 1109 (1487) 1080 (1448)	1294 (1735) 1294 (1735) 1294 (1735) 1255 (1683)	1338 (1794) 1417 (1900) 1417 (1900) 1338 (1794)	2500	575 (1267)
MGX-6620 A	7-40264	0 Ind.	1.55, 1.72, 2.09, 2.28, 2.42 2.73	1106 (1483) 1105 (1482)	1294 (1735) 1248 (1674)	1417 (1900) 1330 (1784)	2500	580 (1278)
MGX-6620 RV	7-40316	—	1.55, 1.72, 2.09, 2.28, 2.42 2.73	1106 (1483) 1105 (1482)	1294 (1735) 1248 (1674)	1417 (1900) 1330 (1784)	2500	510 (1123)
MGX-6650 SC	1002046	0, 00 Ind.	1.51, 1.88, 2.03, 2.37 2.47, 2.93, 3.21	1225 (1643)	1417 (1900)	1464 (1963)	2300 (1.51-2.37) 2500 (2.47-3.21)	1001 (2205)
MGX-6690 SC	1020674	0, 00 Ind.	1.51, 1.88, 2.03, 2.37 2.47, 2.93, 3.21	1225 (1643)	1417 (1900)	1464 (1963)	2300 (1.51-2.37) 2500 (2.47-3.21)	1001 (2205)
MGX-6848 SC	1020675	0, 00 Ind.	1.51, 1.88, 2.03, 2.47 2.58, 2.93 3.21	1591 (2134) 1483 (1989) 1297 (1739)	1828 (2451) 1699 (2278) 1485 (1991)	1985 (2662) 1841 (2469) 1609 (2158)	2300 (1.51-2.03) 2500 (2.47-3.21)	1001 (2205)
				@ 1600 RPM	@ 1800 RPM	@ 2100 RPM		
MG-6984 SC	7-37008 7-37481 P-71034-B	Ind. 0 00	1.18, 1.54, 2.06, 2.29, 2.52 2.92 3.25 3.43	1614 (2164) 1528 (2049) 1269 (1702) 1180 (1582)	1816 (2435) 1719 (2305) 1427 (1914) 1328 (1781)	2119 (2842) 2006 (2690) 1665 (2233) 1549 (2077)	2100	1192 (2628)
MG-6984 A	7-37028 P-71093 P-71094	Ind. 0 00	1.48, 1.97 2.50 2.79 2.93	1602 (2148) 1552 (2081) 1536 (2060) 1512 (2028)	1802 (2416) 1746 (2341) 1728 (2317) 1701 (2281)	2102 (2819) 2037 (2732) 2016 (2703) 1984 (2661)	2100	909 (2000)
MG-6984 RV	7-37042	—	1.48, 1.97 2.50 2.79 2.93	1602 (2148) 1552 (2081) 1536 (2060) 1512 (2028)	1802 (2416) 1746 (2341) 1728 (2317) 1701 (2281)	2102 (2819) 2037 (2732) 2016 (2703) 1984 (2661)	2100	909 (2000)
MG-61242 SC	7-37017	Ind.	1.16, 1.52, 2.08 2.47 2.96	2064 (2768) 2207 (2691) 1950 (2615)	2322 (3114) 2258 (3028) 2193 (2941)	2709 (3633) 2634 (3532) 2559 (3432)	2100	1050 (2310)
MG-61242 A	7-37046	Ind.	1.42, 2.07 2.44 2.93	2090 (2803) 2207 (2691) 1950 (2615)	2351 (3153) 2258 (3028) 2193 (2941)	2743 (3678) 2634 (3532) 2559 (3432)	2100	1105 (2431)
MG-61242 RV	7-37049	—	1.42, 2.07 2.44 2.93	2090 (2803) 2207 (2691) 1950 (2615)	2351 (3153) 2258 (3028) 2193 (2941)	2743 (3678) 2634 (3532) 2559 (3432)	2100	1105 (2431)

Important — See rating definitions, application information, and torsional compatibility notices on pages 19 and 20.
 Ratings shown are in SAE Horsepower (HP). Metric Horsepower equals SAE times 1.014.
 Weights are approximate and include flywheel housing adapter and flexible input coupling.

Consult Twin Disc on light duty ratings for models MG-514C SC/DC, MGX-516 DC, MGX-5170 DC, MG-520-1HP, MGX-5222 DC, MGX-5225 DC, MGX-5321, MG-540, MGX-5600 and other deep ratio units not listed.

INTERMEDIATE DUTY RATINGS FOR STANDARD & QUICKSHIFT® MARINE TRANSMISSIONS



Model	Drawing Number	SAE Housing	Ratios	KILOWATTS (HORSEPOWER)			Maximum Speed (rpm)	Dry Weight (kg (lb))
				@ 2100 RPM	@ 2500 RPM	@ 2800 RPM		
MG-340	IT101317501	5, BW	1.45 2.00 2.60	24 (32) 17 (23) 13 (17)	26 (35) 20 (27) 15 (20)	26 (35) 23 (31) 18 (24)	4500	9 (20)
MG-360	IT101318505	5, BW	1.55 2.00 2.45 2.83	31 (42) 28 (38) 23 (31) 19 (26)	36 (48) 33 (44) 29 (39) 22 (30)	41 (55) 37 (50) 31 (42) 25 (34)	5000	14 (31)
MG-5005 A	IT345ATD0001	3, 4, 5	1.54, 2.00 2.47	47 (63) 35 (47)	56 (75) 41 (55)	63 (85) 47 (63)	4500	25 (55)
MG-5012 SC	IT1013079B01	3, 4, BW	1.52 2.09 2.40 2.78	93 (124) 81 (108) 72 (96) 62 (84)	110 (148) 96 (129) 85 (115) 74 (100)	124 (166) 108 (144) 96 (128) 83 (111)	4500	53 (117)
MG-5020 SC	IT1013049B01	3, 4, BW	1.50, 2.04 2.50 2.94	134 (179) 107 (144) 93 (124)	159 (214) 128 (171) 110 (148)	178 (239) 143 (192) 124 (166)	4000	75 (165)
MG-5025 A	IT1013170	3, 4, BW	1.52, 2.09 2.40	81 (109) 69 (93)	97 (130) 82 (110)	108 (145) 92 (123)	4500	36 (79)
MG-5055 A	IT101316101	3, 4, BW	1.53, 2.08 2.60	147 (197) 99 (135)	175 (235) 118 (160)	196 (263) 132 (179)	4000	54 (119)
MG-5010 DC	PX-9400	3, 4, BW	3.00 3.52 4.00	87 (117) 77 (103) 67 (90)	104 (140) 92 (123) 80 (107)	112 (150) 103 (138) 89 (120)	4000	75 (165)
MG-5011 SC	PX-10270	3, 4, BW	1.11, 1.27, 1.50, 2.00 2.44	112 (150) 92 (124)	123 (165) 112 (150)	127 (170) 119 (160)	4400	49 (109)
MG-5011 A	PX-9999	3, 4, BW	1.44, 1.90 2.39	112 (150) 103 (138)	123 (165) 112 (150)	127 (170) 123 (165)	4400	49 (109)
MG-5011 IV	PX-10290	3, 4, BW	1.14, 1.54, 2.06 2.51	112 (150) 92 (124)	123 (165) 112 (150)	127 (170) 119 (160)	4400	77 (170)
MG-5050 SC	PX-12700	1, 2, 3, 4 SPEC. #3	1.00, 1.23, 1.53, 1.71, 2.04, 2.45 3.00	157 (211) 142 (190)	187 (251) 170 (228)	209 (280) 194 (260)	3300	86 (189)
MG-5050 A	PX-12730	1, 2, 3, 4 SPEC. #3	1.12, 1.26, 1.50, 1.80, 2.04, 2.50	157 (211)	187 (251)	209 (280)	3300	80 (176)
MG-5050 RV	PX-8760	—	1.12, 1.26, 1.50, 1.80, 2.04, 2.50	157 (211)	187 (251)	209 (280)	3300	73 (160)
MG-506-1	XA7022-A XA7048-A	1, 2, 3 1, 2, 3	1.09, 1.50, 1.97 2.50, 2.96	121 (162) 121 (162)	144 (193) 144 (193)	160 (215) 160 (215)	3000 3000	100 (220) 102 (224)
MG-5061 SC	PX-11650/A	1, 2, 3 SPEC. #3	1.15, 1.48, 1.77, 2.00, 2.43, 3.00	201 (270)	239 (320)	261 (350)	3300	98 (215)
MG-5061 A	PX-11640/A	1, 2, 3 SPEC. #3	1.13, 1.28, 1.54, 1.75, 2.00, 2.47	201 (270)	239 (320)	261 (350)	3300	95 (210)
MG-5061 V	PX-8735	—	1.13, 1.28, 1.54, 1.75, 2.00, 2.47	201 (270)	239 (320)	261 (350)	3300	95 (210)
MG-5062 V	PX-11660/A	1, 2, 3 SPEC. #3	1.19, 1.53, 1.83, 2.07, 2.51	201 (270)	239 (320)	261 (350)	3300	142 (312)
MGX-5065 SC	PX-12410	1, 2, 3 SPEC. #3	1.08, 1.26, 1.47, 1.72, 2.04 2.43	279 (374) 254 (341)	329 (441) 302 (405)	367 (492) 338 (453)	3200	111 (244)
MGX-5065 A	PX-12370	1, 2, 3 SPEC. #3	1.08, 1.26, 1.47, 1.72, 2.04 2.43	279 (374) 254 (341)	329 (441) 302 (405)	367 (492) 338 (453)	3200	111 (244)
MG-5065 SC	PX-11480	1, 2, 3 SPEC. #3	1.08, 1.26, 1.47, 1.72, 2.04 2.43	279 (374) 254 (341)	329 (441) 302 (405)	367 (492) 338 (453)	3200	111 (244)
MG-5065 A	PX-11165	1, 2, 3 SPEC. #3	1.08, 1.26, 1.47, 1.72, 2.04 2.43	279 (374) 254 (341)	329 (441) 302 (405)	367 (492) 338 (453)	3200	111 (244)

Important — See rating definitions, application information, and torsional compatibility notices on pages 19 and 20.
 Ratings shown are in SAE Horsepower (HP). Metric Horsepower equals SAE times 1.014.
 Weights are approximate and include flywheel housing adapter and flexible input coupling.

INTERMEDIATE DUTY RATINGS FOR STANDARD & QUICKSHIFT® MARINE TRANSMISSIONS (Continued)



Model	Drawing Number	SAE Housing	Ratios	KILOWATTS (HORSEPOWER)			Maximum Speed (rpm)	Dry Weight (kg (lb))
				@ 2100 RPM	@ 2500 RPM	@ 2800 RPM		
MGX-5075 SC	PX-12620	1, 2, 3 SPEC. #3	1.06, 1.22, 1.33, 1.53, 1.77, 2.05 2.53 2.88	283 (380) 268 (360) 261 (350)	310 (416) 298 (400) 287 (385)	324 (434) 313 (420) 306 (410)	3500	122 (268)
MGX-5075 A	PX-12610	1, 2, 3 SPEC. #3	1.06, 1.22, 1.33, 1.53, 1.77, 2.05 2.53 2.88	283 (380) 268 (360) 261 (350)	310 (416) 298 (400) 287 (385)	324 (434) 313 (420) 306 (410)	3500	122 (268)
MGX-5075 IV	PX-12630	1, 2, 3 SPEC. #3	1.03, 1.30, 1.49, 1.72, 1.99, 2.46	268 (360)	298 (400)	313 (420)	3500	150 (330)
MG-5075 SC	PX-11876	1, 2, 3 SPEC. #3	0.80, 0.92, 1.01, 1.16	268 (360)	298 (400)	313 (420)	3000	122 (268)
MG-5075 SC	PX-10680/A	1, 2, 3 SPEC. #3	1.06, 1.22, 1.33, 1.53, 1.77, 2.05 2.53 2.88	283 (380) 268 (360) 261 (350)	310 (416) 298 (400) 287 (385)	324 (434) 313 (420) 306 (410)	3500	122 (268)
MG-5075 A	PX-10700/A	1, 2, 3 SPEC. #3	1.06, 1.22, 1.33, 1.53, 1.77, 2.05 2.53 2.88	283 (380) 268 (360) 261 (350)	310 (416) 298 (400) 287 (385)	324 (434) 313 (420) 306 (410)	3500	122 (268)
MG-5075 IV	PX-11530	1, 2, 3 SPEC. #3	1.03, 1.30, 1.49, 1.72, 1.99, 2.46	268 (360)	298 (400)	313 (420)	3500	150 (330)
MG-509	X-9816-F	1, 2	1.45, 2.00 2.48 2.95 3.39	235 (315) 235 (315) 216 (290) 165 (220)	273 (366)* 273 (366)* 244 (327)* 190 (255)*	300 (400)* 300 (400)* 265 (355)* 210 (280)*	3000*	259 (572)
	X-9835	1, 2	3.83, 4.50 4.95	235 (315) 180 (242)	279 (374)* 213 (285)*	311 (417)* 235 (315)*	3000*	323 (712)
MG-5085 SC	PX-9260-B/C	1, 2, 3 SPEC. #3	1.05, 1.22, 1.42, 1.76, 1.96 2.33	287 (385) 268 (360)	332 (445) 302 (405)	365 (490) 328 (440)	3200	120 (265)
MG-5085 A	PX-9360-B/C	1, 2, 3 SPEC. #3	1.05, 1.22, 1.47, 1.72, 2.04 2.43	287 (385) 268 (360)	332 (445) 302 (405)	365 (490) 328 (440)	3200	123 (270)
MG-5082 SC	PX-11250-A	1, 2	1.06, 1.33, 1.53, 1.77, 2.05, 2.53 2.88	351 (471) 340 (456)	396 (531) 384 (515)	428 (574) 415 (557)	3200	135 (298)
MG-5082 A	PX-11040-B	1, 2	1.06, 1.33, 1.53, 1.77, 2.05, 2.53 2.88	351 (471) 340 (456)	396 (531) 384 (515)	428 (574) 415 (557)	3200	135 (298)
MGX-5086 SC	PX-12600	1, 2	1.06, 1.33, 1.53, 1.77, 2.05, 2.53 2.88	351 (471) 340 (456)	396 (531) 384 (515)	428 (574) 415 (557)	3200	135 (298)
MGX-5086 A	PX-12290	1, 2	1.06, 1.33, 1.53, 1.77, 2.05, 2.53 2.88	351 (471) 340 (456)	396 (531) 384 (515)	428 (574) 415 (557)	3200	135 (298)
MG-5091 SC	PX-10016	1	1.17, 1.45, 1.71, 2.04 2.45, 2.95 3.33	354 (475) 336 (450) 268 (360)	403 (540) 374 (501) 309 (415)	425 (570) 403 (540) 346 (464)	3000	220 (485)
MG-5091 DC	1002155	1	3.82 4.50 5.05	321 (431) 298 (400) 251 (336)	377 (506) 350 (470) 298 (400)	420 (563) 384 (515) 334 (448)	3000	297 (655)
MG-5090 A	PX-10015	1, 2	1.45, 1.73, 1.96 2.43	343 (460) 321 (430)	365 (490) 343 (460)	382 (512) 359 (481)	3000	216 (475)
				@ 1800 RPM	@ 2100 RPM	@ 2300 RPM		
MGX-5095 SC	PX-12480	1, 2	1.15, 1.27, 1.47, 1.71, 2.00, 2.46 2.95	368 (493) 332 (445)	410 (550) 380 (510)	438 (587) 412 (552)	3000	190 (419)
MGX-5095 A	PX-12360	1, 2	1.28, 1.52, 1.81, 2.04 2.48	367 (492) 336 (451)	410 (550) 380 (510)	438 (587) 409 (548)	3000	185 (407)
MGX-5095 RV	PX-12550	—	1.28, 1.52, 1.81, 2.04 2.48	367 (492) 336 (451)	410 (550) 380 (510)	438 (587) 409 (548)	3000	178 (392)

Important — See rating definitions, application information, and torsional compatibility notices on pages 19 and 20.
 Ratings shown are in SAE Horsepower (HP). Metric Horsepower equals SAE times 1.014.
 Weights are approximate and include flywheel housing adapter and flexible input coupling.

* SAE-14" A6911 driving ring has a 2150 rpm maximum speed.

INTERMEDIATE DUTY RATINGS FOR STANDARD & QUICKSHIFT® MARINE TRANSMISSIONS (Continued)



Model	Drawing Number	SAE Housing	Ratios	KILOWATTS (HORSEPOWER)			Maximum Speed (rpm)	Dry Weight (kg (lb))
				@ 1800 RPM	@ 2100 RPM	@ 2300 RPM		
MG-5095 SC	PX-11535	1, 2	1.15, 1.27, 1.47, 1.71, 2.00, 2.46 2.95	368 (493) 332 (445)	410 (550) 380 (510)	438 (587) 412 (552)	3000	190 (419)
MG-5095 A	PX-11495	1, 2	1.28, 1.52, 1.81, 2.04 2.48	367 (492) 336 (451)	410 (550) 380 (510)	438 (587) 409 (548)	3000	185 (407)
MG-5095 RV	PX-11600	—	1.28, 1.52, 1.81, 2.04 2.48	367 (492) 336 (451)	410 (550) 380 (510)	438 (587) 409 (548)	3000	178 (392)
MGX-5114 SC	PX-12490	1	0.93, 1.02, 1.12, 1.50, 1.74, 2.04 2.54 3.00	448 (601) 410 (550) 380 (510)	504 (676) 466 (625) 451 (605)	552 (740) 500 (671) 492 (660)	2800 at .93:1 3000 for others	203 (447)
MGX-5114 SC-HD	PX-12860	1	1.50, 1.74, 2.04 2.54 3.00	448 (601) 410 (550) 380 (510)	504 (676) 466 (625) 451 (605)	552 (740) 500 (671) 492 (660)	3000	270 (595)
MGX-5114 DC	PX-12170	1	3.28, 3.43, 4.17 4.59 4.86	431 (580) 388 (520) 375 (503)	504 (676) 448 (601) 429 (575)	537 (720) 477 (640) 463 (621)	3000	360 (793)
MGX-5114 A	1024390	1, 2	1.03, 1.20, 1.48, 1.75, 1.92, 2.04 2.50	404 (542) 351 (471)	466 (625) 400 (536)	504 (676) 433 (581)	3000	206 (455)
MGX-5114 RV	PX-11850	—	1.03, 1.20, 1.48, 1.75, 1.92, 2.04 2.50	404 (542) 351 (471)	466 (625) 400 (536)	504 (676) 433 (581)	3000	198 (435)
MGX-5114 IV	PX-12510	1, 2	1.05, 1.23, 1.52, 1.80, 1.97 2.57	404 (542) 351 (471)	466 (625) 400 (536)	504 (676) 433 (581)	3000	270 (595)
MG-5114 SC	PX-9785-B	1	0.93, 1.02, 1.12, 1.50, 1.74, 2.04 2.54 3.00	448 (601) 410 (550) 380 (510)	504 (676) 466 (625) 451 (605)	552 (740) 507 (680) 492 (660)	2800 at .93:1 3000 for others	203 (447)
MG-5114 SC-HD	PX-11962	1	1.50, 1.74, 2.04 2.54 3.00	448 (601) 410 (550) 380 (510)	504 (676) 466 (625) 451 (605)	552 (740) 507 (680) 492 (660)	3000	270 (595)
MG-5114 DC	PX-10250-A PX-12195 (FS)	1 Ind.	3.28, 3.43, 4.17 4.59 4.86	431 (578) 388 (520) 375 (503)	504 (676) 448 (601) 429 (575)	537 (720) 477 (640) 463 (621)	3000	368 (810)
MG-5114 A	PX-11915	1, 2	1.03, 1.20, 1.48, 1.75, 1.92, 2.04 2.50	404 (542) 351 (471)	466 (625) 400 (536)	504 (676) 433 (581)	3000	206 (455)
MG-5114 RV	PX-9830-A	—	1.03, 1.20, 1.48, 1.75, 1.92, 2.04 2.50	404 (542) 351 (471)	466 (625) 400 (536)	504 (676) 433 (581)	3000	198 (435)
MG-5114 IV	PX-11920	1, 2	1.05, 1.23, 1.52, 1.80, 1.97 2.57	404 (542) 351 (471)	466 (625) 400 (536)	504 (676) 433 (581)	3000	270 (595)
MGX-5135 SC	PX-12450	1, 0	1.10, 1.28, 1.48, 1.73, 2.04, 2.57 2.90	529 (709) 493 (661)	560 (751) 522 (700)	600 (805) 560 (751)	2800	284 (625)
MGX-5135 A	PX-12380	1, 0	1.16, 1.25, 1.53, 1.79, 2.00, 2.52	529 (709)	560 (751)	600 (805)	2800	280 (617)
MGX-5135 RV	PX-12520	—	1.16, 1.25, 1.53, 1.79, 2.00, 2.52	529 (709)	560 (751)	600 (805)	2800	258 (568)
MG-5135 SC	PX-11590	1, 0	1.10, 1.28, 1.48, 1.73, 2.04, 2.57 2.90	529 (709) 493 (661)	560 (751) 522 (700)	600 (805) 560 (751)	2800	284 (625)
MG-5135 A	PX-11380	1, 0	1.16, 1.25, 1.53, 1.79, 2.00, 2.52	529 (709)	560 (751)	600 (805)	2800	280 (617)
MG-5135 RV	PX-11945	—	1.16, 1.25, 1.53, 1.79, 2.00, 2.52	529 (709)	560 (751)	600 (805)	2800	258 (568)
MG-514C SC	X-9784-C	1, 0 (14" only)	1.51, 2.00, 2.50, 3.00 3.50	326 (437) 288 (386)	380 (510) 336 (450)	418 (560) 365 (490)	2500	524 (1155)
MG-514C DC	X-9786-C	1, 0 (14" only)	4.13, 4.50, 5.16 6.00	F326 (437) R307 (412) 283 (380)	F380 (510) R358 (480) 330 (442)	F418 (560) R378 (507) 359 (481)	2500	658 (1450)

Important — See rating definitions, application information, and torsional compatibility notices on pages 19 and 20.
 Ratings shown are in SAE Horsepower (HP). Metric Horsepower equals SAE times 1.014.
 Weights are approximate and include flywheel housing adapter and flexible input coupling.

INTERMEDIATE DUTY RATINGS FOR STANDARD & QUICKSHIFT® MARINE TRANSMISSIONS (Continued)



Model	Drawing Number	SAE Housing	Ratios	KILOWATTS (HORSEPOWER)			Maximum Speed (rpm)	Dry Weight (kg (lb))
				@ 1800 RPM	@ 2100 RPM	@ 2300 RPM		
MGX-5145 SC	PX-12460	1, 0	1.03, 1.20, 1.33, 1.48, 1.75, 1.96 2.50	698 (936) 587 (787)	746 (1000) 671 (900)	836 (1121) 726 (974)	2500	325 (716)
MGX-5145 A	PX-12420	1, 0	1.26, 1.48, 1.75, 1.96 2.50	698 (936) 587 (787)	746 (1000) 671 (900)	836 (1121) 726 (974)	2500	333 (734)
MGX-5145 RV	PX-12530	—	1.26, 1.48, 1.75, 1.96 2.50	698 (936) 587 (787)	746 (1000) 671 (900)	836 (1121) 726 (974)	2500	295 (650)
MG-5145 SC	PX-10885	1, 0	1.03, 1.20, 1.33, 1.48, 1.75, 1.96 2.50	698 (936) 587 (787)	746 (1000) 671 (900)	836 (1121) 726 (974)	2500	325 (716)
MG-5145 A	PX-10830	1, 0	1.26, 1.48, 1.75, 1.96 2.50	698 (936) 587 (787)	746 (1000) 671 (900)	836 (1121) 726 (974)	2500	333 (734)
MG-5145 RV	PX-10880	—	1.26, 1.48, 1.75, 1.96 2.50	698 (936) 587 (787)	746 (1000) 671 (900)	836 (1121) 726 (974)	2500	295 (650)
MGX-5147 SC	PX-12470-A	1, 0	1.20, 1.33, 1.48, 1.57, 1.75, 1.96 2.50	753 (1010) 615 (825)	806 (1081) 702 (941)	903 (1211) 760 (1019)	2500	325 (716)
MGX-5147 A	PX-12430-A	1, 0	1.26, 1.48, 1.75, 1.96 2.50	753 (1010) 615 (825)	806 (1081) 702 (941)	903 (1211) 760 (1019)	2500	333 (734)
MGX-5147 RV	PX-12540-A	—	1.03, 1.20, 1.33, 1.48, 1.75, 1.96 2.50	753 (1010) 615 (825)	806 (1081) 702 (941)	903 (1211) 760 (1019)	2500	295 (650)
MGX-516 DC	1023380 (14" only)	1, 0	3.06 3.50 4.04 4.52 5.05 6.00	530 (711) 518 (695) 494 (662) 484 (649) 468 (628) 419 (562)	573 (768) 549 (736) 521 (699) 510 (684) 492 (660) 470 (630)	594 (797) 569 (763) 540 (724) 526 (705) 508 (681) 498 (668)	2500	717 (1580)
MGX-5170 DC	1023382	1, 0	3.12, 3.54, 4.06, 4.50, 5.03, 5.95 6.53, 6.95	537 (720) 467 (626)	578 (775) 545 (731)	578 (775) 561 (752)	2500	850 (1872)
MG-520-1HP	XA-7255-B	0	4.49, 5.00, 6.11 7.00 7.42	718 (963) 667 (894) 623 (835)	837 (1122) 764 (1025) 714 (957)	917 (1230) 828 (1110) 774 (1038)	2500	1559 (3436)
MG-5202 SC	1016103-C	1, 0 Ind.	1.17, 1.33, 1.53, 1.76, 2.03, 2.48, 2.92 3.48	630 (845)	720 (966)	778 (1043)	2750 (2500 at 1.17:1)	587 (1292)
MG-5203 SC	1016249-A	1, 0 Ind.	1.17, 1.33, 1.53, 1.76, 2.03, 2.48, 2.92 3.48	630 (845)	720 (966)	778 (1043)	2750 (2500 at 1.17:1)	409 (900)
MG-5204 SC	1016250-B	1, 0 Ind.	1.17, 1.33, 1.53, 1.76, 2.03, 2.48, 2.92 3.48	727 (975) 630 (845)	858 (1151) 720 (966)	969 (1299) 781 (1047)	2750 (2500 at 1.17:1)	409 (900)
MGX-5222 DC	1022822-A	1, 0 Ind.	4.03, 4.59, 5.04, 6.10, 6.55, 6.96	630 (845)	720 (966)	778 (1043)	2500	1046 (2304)
MGX-5225 DC	1022825-A	1, 0 Ind.	4.03, 4.59, 5.04, 5.57, 6.10	727 (975)	858 (1151)	869 (1165)	2500	1046 (2304)
MGX-5321 DC	1022203-B	0, 00 Ind.	3.35, 4.06, 4.42, 4.96, 5.46, 5.96 6.39	1044 (1400) 893 (1198)	1163 (1560) 1022 (1371)	1178 (1580) 1108 (1486)	2400	1754 (3864)
MG-540 (with rubber block drive)	X-9882-C	0 00, Ind.	1.93, 2.58, 2.90 3.26 3.91 4.10, 4.60 5.17 6.18 7.00 7.47	986 (1322) 902 (1210) 832 (1116) 986 (1322) 886 (1188) 832 (1116) 700 (939) 667 (894)	1055 (1415)* 1005 (1348)* 931 (1248)* 1055 (1415)* 988 (1325)* 931 (1248)* 779 (1045)* 742 (995)*	— 1156 (1550)* 1040 (1395)* — 1119 (1501)* 1040 (1395)* 895 (1200)* 850 (1140)*	1900* 2100* 2400* 1900* 2100* 2400* 2400* 2400*	2105 (4640)

Important — See rating definitions, application information, and torsional compatibility notices on pages 19 and 20.
Ratings shown are in SAE Horsepower (HP). Metric Horsepower equals SAE times 1.014.
Weights are approximate and include flywheel housing adapter and flexible input coupling.

* The max. input speed is 1650 rpm if MG-540 - SAE #00 is used with 21" rubber block drive.

INTERMEDIATE DUTY RATINGS FOR STANDARD & QUICKSHIFT® MARINE TRANSMISSIONS (Continued)



Model	Drawing Number	SAE Housing	Ratios	KILOWATTS (HORSEPOWER)			Maximum Speed (rpm)	Dry Weight (kg (lb))
				@ 1600 RPM	@ 1800 RPM	@ 2100 RPM		
MG-540 (with flexible coupling)	X-9882-C	0 00, Ind.	1.93, 2.58, 2.90, 3.26	1049 (1407)	1180 (1582)	—	1900	2105 (4640)
			3.91	893 (1198)	1011 (1356)	1193 (1600)	2400	
			4.10, 4.60	1049 (1407)	1180 (1582)	—	1900	
			5.17	1038 (1392)	1168 (1566)	1362 (1826)	2100	
			6.18	867 (1163)	975 (1307)	1138 (1526)	2400	
			7.00	766 (1027)	861 (1155)	1005 (1348)	2400	
			7.47	718 (963)	808 (1084)	943 (1265)	2400	
MG-5506	00D005604	0, 00 Ind.	4.03, 4.55, 4.96, 5.44 6.00	1323 (1774) 1197 (1605)	1489 (1998) 1347 (1806)	—	2000	2200 (4846)
MGX-5600	1022780	0, 00 Ind.	2.53, 2.98, 3.51, 4.03	1602 (2148)	1805 (2421)	2105 (2823)	2100	3132 (6890)
			4.63, 5.04	1602 (2148)	1805 (2421)	2095 (2809)		
			5.76	1598 (2143)	1760 (2360)	1770 (2374)		
			6.04	1353 (1814)	1502 (2014)	1717 (2302)		
				@ 1800 RPM	@ 2100 RPM	@ 2300 RPM		
MG-6449 A	7-37423	1, 0 Ind.	1.51, 1.73	769 (1031)	897 (1203)	958 (1285)	2500	344 (757)
			2.07	639 (857)	746 (1000)	794 (1065)		
			2.44	555 (744)	647 (868)	692 (928)		
			2.95	496 (665)	577 (774)	617 (828)		
MG-6449 RV	7-37431-A	—	1.51, 1.73	769 (1031)	897 (1203)	958 (1285)	2500	325 (716)
			2.07	639 (857)	746 (1000)	794 (1065)		
			2.44	555 (744)	647 (868)	692 (928)		
			2.95	496 (665)	577 (774)	617 (828)		
MGX-6598 DC	7-40379	1, 0 Ind.	2.46, 3.03	882 (1183)	1000 (1341)	1067 (1431)	2500	580 (1278)
			3.48	849 (1139)	945 (1267)	1008 (1352)		
			3.93	774 (1038)	861 (1155)	918 (1231)		
			4.43	722 (968)	804 (1078)	857 (1149)		
MGX-6599 SC	7-40384	1, 0 Ind.	1.07, 1.30, 1.50, 1.66, 1.74, 1.97, 2.04	862 (1156)	960 (1287)	1023 (1372)	2500	492 (1084)
			2.19, 2.45	844 (1132)	940 (1261)	1002 (1344)		
			2.82	728 (976)	811 (1088)	864 (1159)		
MGX-6599 A	7-40263	1, 0 Ind.	1.34, 1.51, 1.74, 2.03, 2.24	890 (1193)	992 (1330)	1057 (1417)	2500	488 (1075)
			2.48	841 (1128)	937 (1257)	999 (1340)		
			2.80	815 (1093)	908 (1218)	967 (1297)		
MGX-6599 RV	7-40336	—	1.34, 1.51, 1.74, 2.03, 2.24	890 (1193)	992 (1330)	1057 (1417)	2500	468 (1031)
			2.48	841 (1128)	937 (1257)	999 (1340)		
			2.80	815 (1093)	908 (1218)	967 (1297)		
MG-6600 DC	7-36712-A	0 Ind.	3.30	819 (1098)	955 (1281)	1046 (1403)	2500	794 (1747)
			4.11	819 (1098)	955 (1281)	1018 (1365)		
			4.68, 4.72	777 (1042)	906 (1215)	966 (1295)		
			5.21	693 (929)	809 (1085)	886 (1188)		
			6.05	617 (828)	719 (964)	788 (1057)		
MGX-6620 SC	7-40337	0 Ind.	1.15, 1.33, 1.53, 1.73	1047 (1404)	1166 (1564)	1191 (1597)	2500	575 (1267)
			2.03	1025 (1375)	1142 (1531)	1184 (1588)		
			2.32	1019 (1366)	1136 (1523)	1184 (1588)		
			2.44	987 (1324)	1100 (1475)	1172 (1572)		
			2.72	915 (1227)	1019 (1366)	1086 (1456)		
MGX-6620 A	7-40264	0 Ind.	1.55, 1.72, 2.09	1103 (1479)	1234 (1655)	1315 (1763)	2500	580 (1278)
			2.28, 2.42	1028 (1379)	1145 (1535)	1220 (1636)		
			2.73	910 (1220)	1014 (1360)	1080 (1448)		
MGX-6620 RV	7-40316	—	1.55, 1.72, 2.09	1103 (1479)	1234 (1655)	1315 (1763)	2500	510 (1123)
			2.28, 2.42	1028 (1379)	1145 (1535)	1220 (1636)		
			2.73	910 (1220)	1014 (1360)	1080 (1448)		

Important — See rating definitions, application information, and torsional compatibility notices on pages 19 and 20.
 Ratings shown are in SAE Horsepower (HP). Metric Horsepower equals SAE times 1.014.
 Weights are approximate and include flywheel housing adapter and flexible input coupling.

**INTERMEDIATE DUTY RATINGS FOR STANDARD &
QUICKSHIFT® MARINE TRANSMISSIONS (Continued)**



Model	Drawing Number	SAE Housing	Ratios	KILOWATTS (HORSEPOWER)			Maximum Speed (rpm)	Dry Weight (kg (lb))
				@ 1800 RPM	@ 2100 RPM	@ 2300 RPM		
MGX-6650 SC	1002046	0, 00 Ind.	1.51, 1.88, 2.03, 2.37 2.47, 2.93, 3.21	1069 (1434)	1268 (1700)	1386 (1859)	2300 (1.51–2.37) 2500 (2.47–3.21)	1001 (2205)
MGX-6690 SC	1020674	0, 00 Ind.	1.51, 1.88, 2.03, 2.37, 2.47 2.93 3.21	1201 (1611) 1201 (1611) 1201 (1611)	1380 (1851) 1318 (1767) 1280 (1716)	1438 (1928) 1386 (1859) 1386 (1859)	2300 (1.51–2.37) 2500 (2.47–3.21)	1001 (2205)
MGX-6848 SC	1020675	0, 00 Ind.	1.51, 1.88, 2.03, 2.47, 2.58, 2.93 3.21	1342 (1800) 1269 (1702)	1566 (2100) 1453 (1948)	1715 (2300) 1575 (2112)	2300 (1.51–2.03) 2500 (2.47–3.21)	1001 (2205)
				@ 1600 RPM	@ 1800 RPM	@ 2100 RPM		
MG-6984 SC	7-37008 7-37481 P-71034-B	Ind. 0 00	1.18, 1.54, 2.06, 2.29, 2.52, 2.92 3.25 3.43	1470 (1971) 1244 (1668) 1000 (1341)	1654 (2218) 1399 (1876) 1125 (1509)	1929 (2587) 1632 (2189) 1313 (1761)	2100	1192 (2628)
MG-6984 A	7-37028 P-71093 P-71094	Ind. 0 00	1.48, 1.97, 2.50, 2.79 2.93	1504 (2017) 1462 (1961)	1692 (2269) 1645 (2206)	1974 (2647) 1919 (2573)	2100	909 (2000)
MG-6984 RV	7-37042	—	1.48, 1.97, 2.50, 2.79 2.93	1504 (2017) 1462 (1961)	1692 (2269) 1645 (2206)	1974 (2647) 1919 (2573)	2100	909 (2000)
MG-61242 SC	7-37017	Ind.	1.16, 1.52, 2.08 2.47 2.96	2001 (2683) 1960 (2628) 1949 (2614)	2251 (3019) 2205 (2957) 2193 (2941)	2626 (3521) 2571 (3448) 2559 (3432)	2100	1050 (2310)
MG-61242 A	7-37046	Ind.	1.42, 2.07 2.44, 2.93	2078 (2787) 1949 (2614)	2338 (3135) 2193 (2941)	2728 (3658) 2559 (3432)	2100	1105 (2431)
MG-61242 RV	7-37049	—	1.42, 2.07 2.44, 2.93	2078 (2787) 1949 (2614)	2338 (3135) 2193 (2941)	2728 (3658) 2559 (3432)	2100	1105 (2431)

Important — See rating definitions, application information, and torsional compatibility notices on pages 19 and 20.
Ratings shown are in SAE Horsepower (HP). Metric Horsepower equals SAE times 1.014.
Weights are approximate and include flywheel housing adapter and flexible input coupling.

MEDIUM DUTY RATINGS FOR STANDARD & QUICKSHIFT® MARINE TRANSMISSIONS



Model	Drawing Number	SAE Housing	Ratios	KILOWATTS (HORSEPOWER)			Maximum Speed (rpm)	Dry Weight (kg (lb))
				@ 1800 RPM	@ 2100 RPM	@ 2300 RPM		
MG-5011 SC	PX-10270	3, 4, BW	1.11, 1.27, 1.50, 2.00 2.44	74 (99) 57 (77)	82 (110) 74 (99)	90 (121) 82 (110)	4400	49 (109)
MG-5011 A	PX-9999	3, 4, BW	1.44, 1.90 2.39	74 (99) 66 (89)	82 (110) 74 (99)	90 (121) 82 (110)	4400	49 (109)
MG-5011 IV	PX-10290	3, 4, BW	1.14, 1.54, 2.06 2.51	74 (99) 57 (77)	82 (110) 66 (89)	90 (121) 74 (99)	4400	77 (170)
MG-5050 SC	PX-12700	1, 2, 3, 4 SPEC. #3	1.00, 1.23, 1.53, 1.71, 2.04, 2.45 3.00	115 (154) 102 (137)	128 (172) 119 (160)	140 (188) 133 (178)	3300	86 (189)
MG-5050 A	PX-12730	1, 2, 3, 4 SPEC. #3	1.12, 1.26, 1.50, 1.80, 2.04, 2.50	115 (154)	128 (172)	140 (188)	3300	80 (176)
MG-5050 RV	PX-8760	—	1.12, 1.26, 1.50, 1.80, 2.04, 2.50	115 (154)	128 (172)	140 (188)	3300	73 (160)
MG-5061 SC	PX-11650/A	1, 2, 3 SPEC. #3	1.15, 1.48, 1.77, 2.00, 2.43 3.00	135 (181) 126 (169)	157 (211) 147 (197)	171 (229) 160 (215)	3300	98 (215)
MG-5061 A	PX-11640/A	1, 2, 3 SPEC. #3	1.13, 1.28, 1.54, 1.75, 2.00 2.47	135 (181) 126 (169)	157 (211) 147 (197)	171 (229) 160 (215)	3300	95 (210)
MG-5061 V	PX-8735	—	1.13, 1.28, 1.54, 1.75, 2.00 2.47	135 (181) 126 (169)	157 (211) 147 (197)	171 (229) 160 (215)	3300	95 (210)
MG-5062 V	PX-11660/A	1, 2, 3 SPEC. #3	1.19, 1.53, 1.83, 2.07, 2.51	135 (181)	157 (211)	171 (229)	3300	142 (312)
MGX-5065 SC	PX-12410	1, 2, 3 SPEC. #3	1.08, 1.26, 1.47, 1.72, 2.04 2.43	227 (304) 208 (279)	262 (351) 243 (326)	285 (382) 266 (357)	3200	111 (244)
MGX-5065 A	PX-12370	1, 2, 3 SPEC. #3	1.08, 1.26, 1.47, 1.72, 2.04 2.43	227 (304) 208 (279)	262 (351) 243 (326)	285 (382) 266 (357)	3200	111 (244)
MG-5065 SC	PX-11480	1, 2, 3 SPEC. #3	1.08, 1.26, 1.47, 1.72, 2.04 2.43	227 (304) 208 (279)	262 (351) 243 (326)	285 (382) 266 (357)	3200	111 (244)
MG-5065 A	PX-11165	1, 2, 3 SPEC. #3	1.08, 1.26, 1.47, 1.72, 2.04 2.43	227 (304) 208 (279)	262 (351) 243 (326)	285 (382) 266 (357)	3200	111 (244)
MGX-5075 SC	PX-12620	1, 2, 3 SPEC. #3	1.06, 1.22, 1.33, 1.53, 1.77, 2.05 2.53, 2.88	205 (275)	230 (308)	246 (330)	3500	122 (268)
MGX-5075 A	PX-12610	1, 2, 3 SPEC. #3	1.06, 1.22, 1.33, 1.53, 1.77, 2.05 2.53, 2.88	205 (275)	230 (308)	246 (330)	3500	122 (268)
MGX-5075 IV	PX-12630	1, 2, 3 SPEC. #3	1.03, 1.30, 1.49, 1.72, 1.99, 2.46	205 (275)	230 (308)	246 (330)	3500	150 (330)
MG-5075 SC	PX-10680/A	1, 2, 3 SPEC. #3	1.06, 1.22, 1.33, 1.53, 1.77, 2.05 2.53, 2.88	205 (275)	230 (308)	246 (330)	3500	122 (268)
MG-5075 A	PX-10700/A	1, 2, 3 SPEC. #3	1.06, 1.22, 1.33, 1.53, 1.77, 2.05 2.53, 2.88	205 (275)	230 (308)	246 (330)	3500	122 (268)
MG-5075 IV	PX-11530	1, 2, 3 SPEC. #3	1.03, 1.30, 1.49, 1.72, 1.99, 2.46	205 (275)	230 (308)	246 (330)	3500	150 (330)
MG-5085 SC	PX-9260-B/C	1, 2, 3 SPEC. #3	1.05, 1.22, 1.42, 1.76, 1.96 2.33	250 (335) 225 (302)	279 (375) 254 (341)	295 (396) 271 (363)	3200	120 (265)
MG-5085 A	PX-9360-B/C	1, 2, 3 SPEC. #3	1.05, 1.22, 1.47, 1.72, 2.04 2.43	250 (335) 217 (291)	279 (375) 248 (333)	295 (396) 268 (360)	3200	123 (270)
MG-5082 SC	PX-11250-A	1, 2	1.06, 1.33, 1.53, 1.77, 2.05, 2.53 2.88	301 (404) 273 (366)	336 (451) 313 (420)	350 (469) 331 (444)	3200	135 (298)
MG-5082 A	PX-11040-B	1, 2	1.06, 1.33, 1.53, 1.77, 2.05, 2.53 2.88	301 (404) 273 (366)	336 (451) 313 (420)	350 (469) 331 (444)	3200	135 (298)
MGX-5086 SC	PX-12600	1, 2	1.06, 1.33, 1.53, 1.77, 2.05, 2.53 2.88	301 (404) 273 (366)	336 (451) 313 (420)	350 (469) 331 (444)	3200	135 (298)
MGX-5086 A	PX-12290	1, 2	1.06, 1.33, 1.53, 1.77, 2.05, 2.53 2.88	301 (404) 273 (366)	336 (451) 313 (420)	350 (469) 331 (444)	3200	135 (298)

Important — See rating definitions, application information, and torsional compatibility notices on pages 19 and 20.
 Ratings shown are in SAE Horsepower (HP). Metric Horsepower equals SAE times 1.014.
 Weights are approximate and include flywheel housing adapter and flexible input coupling.

MEDIUM DUTY RATINGS FOR STANDARD & QUICKSHIFT® MARINE TRANSMISSIONS (Continued)



Model	Drawing Number	SAE Housing	Ratios	KILOWATTS (HORSEPOWER)			Maximum Speed (rpm)	Dry Weight (kg (lb))
				@ 1800 RPM	@ 2100 RPM	@ 2300 RPM		
MG-5091 SC	PX-10016	1, 2	1.17, 1.45, 1.71, 2.04 2.45, 2.95 3.33	274 (368) 265 (355) 219 (293)	317 (425) 308 (413) 254 (340)	347 (465) 330 (443) 274 (368)	3000	220 (485)
MG-5091 DC	1002155	1, 2	3.82, 4.50 5.05	262 (351) 210 (281)	303 (406) 245 (328)	330 (443) 268 (359)	3000	297 (655)
MG-5090 A	PX-10015	1, 2	1.45, 1.73, 1.96 2.43	267 (358) 250 (335)	309 (415) 291 (390)	321 (430) 302 (405)	3000	216 (475)
MGX-5095 SC	PX-12480	1, 2	1.15, 1.27, 1.47, 1.71, 2.00, 2.46 2.95	336 (451) 319 (428)	374 (502) 360 (483)	399 (535) 385 (516)	3000	190 (419)
MGX-5095 A	PX-12360	1, 2	1.28, 1.52, 1.81, 2.04, 2.48	319 (428)	358 (480)	385 (516)	3000	185 (407)
MGX-5095 RV	PX-12550	—	1.28, 1.52, 1.81, 2.04, 2.48	319 (428)	358 (480)	385 (516)	3000	178 (392)
MG-5095 SC	PX-11535	1, 2	1.15, 1.27, 1.47, 1.71, 2.00, 2.46 2.95	336 (451) 319 (428)	374 (502) 360 (483)	399 (535) 385 (516)	3000	190 (419)
MG-5095 A	PX-11495	1, 2	1.28, 1.52, 1.81, 2.04, 2.48	319 (428)	358 (480)	385 (516)	3000	185 (407)
MG-5095 RV	PX-11600	—	1.28, 1.52, 1.81, 2.04, 2.48	319 (428)	358 (480)	385 (516)	3000	178 (392)
MGX-5114 SC	PX-12490	1	0.93, 1.02, 1.12, 1.50, 1.74 2.04, 2.54 3.00	394 (528) 394 (528) 361 (484)	451 (605) 451 (605) 410 (550)	489 (656) 489 (656) 443 (595)	2800 at .93:1 3000 for others	203 (447)
MGX-5114 SC-HD	PX-12860	1	1.50, 1.74 2.04, 2.54 3.00	394 (528) 394 (528) 361 (484)	451 (605) 451 (605) 410 (550)	489 (656) 489 (656) 443 (595)	3000	270 (595)
MGX-5114 DC	PX-12170	1	3.28, 3.43, 4.17, 4.59, 4.86	361 (484)	419 (562)	437 (586)	3000	360 (793)
MGX-5114 A	1024390	1, 2	1.03, 1.20, 1.48, 1.75, 1.92, 2.04 2.50	357 (479) 338 (453)	407 (546) 385 (516)	440 (590) 417 (559)	3000	206 (455)
MGX-5114 RV	PX-11850	—	1.03, 1.20, 1.48, 1.75, 1.92, 2.04 2.50	357 (479) 338 (453)	407 (546) 385 (516)	440 (590) 417 (559)	3000	198 (435)
MGX-5114 IV	PX-12510	1, 2	1.05, 1.23, 1.52, 1.80, 1.97 2.57	357 (479) 338 (453)	407 (546) 385 (516)	440 (590) 417 (559)	3000	270 (595)
MG-5114 SC	PX-9785-B	1	0.93, 1.02, 1.12, 1.50, 1.74 2.04, 2.54 3.00	394 (528) 394 (528) 361 (484)	451 (605) 451 (605) 410 (550)	489 (656) 489 (656) 443 (595)	2800 at .93:1 3000 for others	203 (447)
MG-5114 SC-HD	PX-11962	1	1.50, 1.74 2.04, 2.54 3.00	394 (528) 394 (528) 361 (484)	451 (605) 451 (605) 410 (550)	489 (656) 489 (656) 443 (595)	3000	270 (595)
MG-5114 DC	PX-10250-A PX-12195(FS)	1 Ind.	3.28, 3.43, 4.17, 4.59, 4.86	361 (484)	419 (562)	437 (586)	3000	368 (810)
MG-5114 A	PX-11915	1, 2	1.03, 1.20, 1.48, 1.75, 1.92, 2.04 2.50	357 (479) 338 (453)	407 (546) 385 (516)	440 (590) 417 (559)	3000	206 (455)
MG-5114 RV	PX-9830-A	—	1.03, 1.20, 1.48, 1.75, 1.92, 2.04 2.50	357 (479) 338 (453)	407 (546) 385 (516)	440 (590) 417 (559)	3000	198 (435)
MG-5114 IV	PX-11920	1, 2	1.05, 1.23, 1.52, 1.80, 1.97 2.57	357 (479) 338 (453)	407 (546) 385 (516)	440 (590) 417 (559)	3000	270 (595)
MG-514C SC	X-9784-C	1, 0 (14" only)	1.51, 2.00, 2.50 3.00 3.50	328 (440)* 306 (410) 283 (380)	358 (480)* 336 (450) 313 (420)	377 (505)* 354 (475) 332 (445)	2500	524 (1155)
MG-514C DC	X-9786-C	1, 4 (14" only)	4.13, 4.50, 5.16 6.04	298 (400) 272 (365)	334 (448) 309 (415)	358 (480) 347 (465)	2500	658 (1450)

Important — See rating definitions, application information, and torsional compatibility notices on pages 19 and 20.
Ratings shown are in SAE Horsepower (HP). Metric Horsepower equals SAE times 1.014.
Weights are approximate and include flywheel housing adapter and flexible input coupling.

* Requires 230 PSI coolant pressure.

MEDIUM DUTY RATINGS FOR STANDARD & QUICKSHIFT® MARINE TRANSMISSIONS (Continued)



Model	Drawing Number	SAE Housing	Ratios	KILOWATTS (HORSEPOWER)			Maximum Speed (rpm)	Dry Weight (kg (lb))
				@ 1600 RPM	@ 1800 RPM	@ 2100 RPM		
MGX-5135 SC	PX-12450	1, 0	1.10, 1.28, 1.48, 1.73, 2.04, 2.57 2.90	447 (599) 413 (554)	485 (650) 448 (601)	542 (727) 500 (671)	2800	284 (625)
MGX-5135 A	PX-12380	1, 0	1.16, 1.25, 1.53, 1.79, 2.00, 2.52	447 (599)	485 (650)	542 (727)	2800	280 (617)
MGX-5135 RV	PX-12520	—	1.16, 1.25, 1.53, 1.79, 2.00, 2.52	447 (599)	485 (650)	542 (727)	2800	258 (568)
MG-5135 SC	PX-11590	1, 0	1.10, 1.28, 1.48, 1.73, 2.04, 2.57 2.90	447 (599) 413 (554)	485 (650) 448 (601)	542 (727) 500 (671)	2800	284 (625)
MG-5135 A	PX-11380	1, 0	1.16, 1.25, 1.53, 1.79, 2.00, 2.52	447 (599)	485 (650)	542 (727)	2800	280 (617)
MG-5135 RV	PX-11945	—	1.16, 1.25, 1.53, 1.79, 2.00, 2.52	447 (599)	485 (650)	542 (727)	2800	258 (568)
MGX-5145 SC	PX-12460	1, 0	1.03, 1.20, 1.33, 1.48, 1.75, 1.96 2.50	553 (742) 473 (634)	596 (800) 522 (700)	637 (854) 597 (801)	2500	325 (716)
MGX-5145 A	PX-12420	1, 0	1.26, 1.48, 1.75, 1.96 2.50	553 (742) 473 (634)	596 (800) 522 (700)	637 (854) 597 (801)	2500	333 (734)
MGX-5145 RV	PX-12530	—	1.26, 1.48, 1.75, 1.96 2.50	553 (742) 473 (634)	596 (800) 522 (700)	637 (854) 597 (801)	2500	295 (650)
MG-5145 SC	PX-10885	1, 0	1.03, 1.20, 1.33, 1.48, 1.75, 1.96 2.50	553 (742) 473 (634)	596 (800) 522 (700)	637 (854) 597 (801)	2500	325 (716)
MG-5145 A	PX-10830	1, 0	1.26, 1.48, 1.75, 1.96 2.50	553 (742) 473 (634)	596 (800) 522 (700)	637 (854) 597 (801)	2500	333 (734)
MG-5145 RV	PX-10880	—	1.26, 1.48, 1.75, 1.96 2.50	553 (742) 473 (634)	596 (800) 522 (700)	637 (854) 597 (801)	2500	295 (650)
MGX-5147 SC	PX-12470-A	1, 0	1.20, 1.33, 1.48, 1.57, 1.75, 1.96 2.50	623 (835) 500 (671)	671 (900) 552 (740)	714 (957) 631 (846)	2500	325 (716)
MGX-5147 A	PX-12430-A	1, 0	1.26, 1.48, 1.75, 1.96 2.50	623 (835) 500 (671)	671 (900) 552 (740)	714 (957) 631 (846)	2500	333 (734)
MGX-5147 RV	PX-12540-A	—	1.03, 1.20, 1.33, 1.48, 1.75, 1.96 2.50	623 (835) 500 (671)	671 (900) 552 (740)	714 (957) 631 (846)	2500	295 (650)
MGX-516 DC	1023380	1, 0 (14" only)	3.07, 3.50, 4.04, 4.52, 5.05 6.00	397 (532) 365 (489)	447 (600) 406 (544)	465 (624) 425 (570)	2500	717 (1580)
MGX-5170 DC	1023382	1, 0	3.12, 3.54, 4.06, 4.50, 5.03, 5.95 6.53, 6.95	475 (637) 415 (557)	537 (720) 499 (615)	578 (775) 499 (669)	2500	850 (1872)
MG-520-1HP	XA-7255-B	0	4.49, 5.00, 6.11 7.00 7.42	609 (817) 580 (778) 542 (727)	685 (919) 645 (865) 603 (809)	799 (1071) 739 (991) 691 (927)	2500	1559 (3436)
MG-5202 SC	1016103-C	1, 0 Ind.	1.17, 1.33, 1.53, 1.76, 2.03 2.48, 2.92, 3.48	540 (724)	600 (805)	678 (909)	2500	587 (1292)
MG-5203 SC	1016249-A	1, 0 Ind.	1.17, 1.33, 1.53, 1.76, 2.03 2.48, 2.92, 3.48	540 (724)	600 (805)	678 (909)	2500	409 (900)
MG-5204 SC	1016250-B	1, 0 Ind.	1.17, 1.33, 1.53, 1.76, 2.03, 2.48, 2.92 3.48	633 (849) 540 (724)	716 (960) 600 (805)	797 (1069) 678 (909)	2750 (2500 at 1.17:1)	409 (900)
MGX-5222 DC	1022822-A	1, 0 Ind.	4.03, 4.59, 5.04, 6.10, 6.55, 6.96	540 (724)	600 (805)	678 (909)	2500	1046 (2304)
MGX-5225 DC	1022825-A	1, 0 Ind.	4.03, 4.59, 5.04, 5.57, 6.10	644 (864)	727 (975)	787 (1055)	2500	1046 (2304)
MGX-5321 DC	1022203-B	0, 00 Ind.	3.35, 4.06, 4.42, 4.96, 5.46 5.96 6.39	928 (1244) 865 (1160) 776 (1041)	1044 (1400) 956 (1282) 863 (1157)	1069 (1434) 1035 (1388) 967 (1297)	2400	1754 (3864)
MG-540 (with rubber block drive)	X-9882-C	0 00, Ind.	1.93, 2.58, 2.90 3.26 3.91 4.10, 4.60 5.17 6.18 7.00 7.47	746 (1000) 666 (893) 597 (800) 732 (982) 662 (888) 636 (853) 519 (696) 492 (660)	924 (1239) 855 (1147) 776 (1041) 917 (1230) 847 (1136) 820 (1100) 681 (913) 651 (873)	999 (1340)* 950 (1274)* 866 (1161)* 990 (1328)* 941 (1262)* 913 (1224)* 762 (1022)* 740 (992)*	1900* 2100* 2400* 1900* 2100* 2400* 2400* 2400*	2019 (4450) 2105 (4640)

Important — See rating definitions, application information, and torsional compatibility notices on pages 19 and 20.
 Ratings shown are in SAE Horsepower (HP). Metric Horsepower equals SAE times 1.014.
 Weights are approximate and include flywheel housing adapter and flexible input coupling.

* The max. input speed is 1650 rpm if MG-540 - SAE #00 is used with 21" rubber block drive.

MEDIUM DUTY RATINGS FOR STANDARD & QUICKSHIFT® MARINE TRANSMISSIONS (Continued)



Model	Drawing Number	SAE Housing	Ratios	KILOWATTS (HORSEPOWER)			Maximum Speed (rpm)	Dry Weight (kg (lb))
				@ 1200 RPM	@ 1600 RPM	@ 1800 RPM		
MG-540 (with flexible coupling)	X-9882-C	0 00, Ind.	1.93, 2.58, 2.90	787 (1055)	1049 (1407)	1180 (1582)	1900	2019 (4450) 2105 (4640)
			3.26	869 (1165)	1034 (1387)	1163 (1560)	2100	
			3.91	648 (869)	864 (1159)	972 (1303)	2400	
			4.10, 4.60	787 (1055)	1049 (1407)	1180 (1582)	1900	
			5.17	774 (1038)	1032 (1384)	1161 (1557)	2100	
			6.18	644 (864)	859 (1152)	966 (1295)	2400	
			7.00	571 (766)	762 (1022)	857 (1149)	2400	
			7.47	535 (717)	715 (959)	804 (1078)	2400	
MG-5506	000005604	0, 00 Ind.	4.03, 4.55, 4.96, 5.44 6.00	960 (1287) 869 (1165)	1281 (1718) 1159 (1554)	1441 (1932) 1304 (1749)	2000	2200 (4846)
MGX-5600	1022780	0, 00 Ind.	2.53, 2.98, 3.51, 4.03, 4.63, 5.04 5.76 6.04	1230 (1649) 1200 (1609) 1016 (1362)	1598 (2143) 1566 (2100) 1309 (1755)	1760 (2360) 1737 (2329) 1451 (1946)	2100	3132 (6890)
				@ 1600 RPM	@ 1800 RPM	@ 2100 RPM		
MG-6449 A	7-37423	1, 0 Ind.	1.51, 1.73	680 (912)	741 (994)	833 (1117)	2500	344 (757)
			2.07	565 (758)	617 (827)	695 (932)		
			2.44	494 (662)	537 (720)	602 (807)		
			2.95	435 (583)	489 (656)	570 (764)		
MG-6449 RV	7-37431-A	—	1.51, 1.73	680 (912)	741 (994)	833 (1117)	2500	325 (716)
			2.07	565 (758)	617 (827)	695 (932)		
			2.44	494 (662)	537 (720)	602 (807)		
			2.95	435 (583)	489 (656)	570 (764)		
MGX-6598 DC	7-40379	1, 0 Ind.	2.46, 3.03	759 (1018)	824 (1105)	918 (1231)	2500	580 (1278)
			3.48	717 (961)	779 (1045)	868 (1164)		
			3.93	653 (876)	710 (952)	790 (1059)		
			4.43	609 (817)	662 (888)	737 (988)		
MGX-6599 SC	7-40384	1, 0 Ind.	1.07, 1.30, 1.50, 1.66, 1.74, 1.97, 2.04 2.19, 2.45 2.82	713 (956) 713 (956) 615 (825)	774 (1038) 774 (1038) 668 (896)	862 (1156) 862 (1156) 744 (998)	2500	492 (1084)
			1.34, 1.51, 1.74, 2.03, 2.24 2.48 2.80	754 (1011) 711 (953) 654 (877)	820 (1100) 772 (1035) 709 (951)	910 (1220) 860 (1153) 790 (1059)		
			1.34, 1.51, 1.74, 2.03, 2.24 2.48 2.80	754 (1011) 711 (953) 654 (877)	820 (1100) 772 (1035) 709 (951)	910 (1220) 860 (1153) 790 (1059)		
			3.30, 4.11 4.68, 4.72 5.22 6.05	884 (1185) 861 (1155) 834 (1118) 773 (1037)	960 (1287) 935 (1254) 906 (1215) 839 (1125)	998 (1338) 998 (1338) 998 (1338) 935 (1254)		
MG-6600 DC	7-36712-A	0 Ind.	1.15, 1.33, 1.53, 1.73 2.03, 2.32 2.44 2.72	884 (1185) 861 (1155) 834 (1118) 773 (1037)	960 (1287) 935 (1254) 906 (1215) 839 (1125)	998 (1338) 998 (1338) 998 (1338) 935 (1254)	2500	794 (1747)
			1.55, 1.72, 2.09 2.28, 2.42 2.73	926 (1242) 868 (1164) 769 (1031)	1021 (1369) 943 (1265) 835 (1120)	1132 (1518) 1050 (1408) 930 (1247)		
			1.55, 1.72, 2.09 2.28, 2.42 2.73	926 (1242) 868 (1164) 769 (1031)	1021 (1369) 943 (1265) 835 (1120)	1132 (1518) 1050 (1408) 930 (1247)		
			1.55, 1.72, 2.09 2.28, 2.42 2.73	926 (1242) 868 (1164) 769 (1031)	1021 (1369) 943 (1265) 835 (1120)	1132 (1518) 1050 (1408) 930 (1247)		
MGX-6620 A	7-40264	0 Ind.	1.55, 1.72, 2.09 2.28, 2.42 2.73	926 (1242) 868 (1164) 769 (1031)	1021 (1369) 943 (1265) 835 (1120)	1132 (1518) 1050 (1408) 930 (1247)	2500	580 (1278)
MGX-6620 RV	7-40316	—	1.55, 1.72, 2.09 2.28, 2.42 2.73	926 (1242) 868 (1164) 769 (1031)	1021 (1369) 943 (1265) 835 (1120)	1132 (1518) 1050 (1408) 930 (1247)	2500	510 (1123)

Important — See rating definitions, application information, and torsional compatibility notices on pages 19 and 20.
Ratings shown are in SAE Horsepower (HP). Metric Horsepower equals SAE times 1.014.
Weights are approximate and include flywheel housing adapter and flexible input coupling.

MEDIUM DUTY RATINGS FOR STANDARD & QUICKSHIFT® MARINE TRANSMISSIONS (Continued)



Model	Drawing Number	SAE Housing	Ratios	KILOWATTS (HORSEPOWER)			Maximum Speed (rpm)	Dry Weight (kg (lb))
				@ 1600 RPM	@ 1800 RPM	@ 2100 RPM		
MGX-6650 SC	1002046	0, 00 Ind.	1.51, 1.88, 2.03, 2.37 2.47, 2.93, 3.21	928 (1244)	1044 (1400)	1174 (1574)	2300 (1.51-2.37) 2500 (2.47-3.21)	1001 (2205)
MGX-6690 SC	1020674	0, 00 Ind.	1.51, 1.88, 2.03, 2.37, 2.47 2.93 3.21	1054 (1413) 1034 (1387) 1018 (1365)	1174 (1574) 1144 (1534) 1119 (1501)	1277 (1712) 1209 (1621) 1194 (1601)	2300 (1.51-2.37) 2500 (2.47-3.21)	1001 (2205)
MGX-6848 SC	1020675	0, 00 Ind.	1.51, 1.88, 2.03, 2.47 2.58, 2.93 3.21	1187 (1592) 1187 (1592) 1103 (1479)	1342 (1800) 1342 (1800) 1226 (1644)	1566 (2100) 1518 (2036) 1404 (1883)	2300 (1.51-2.03) 2500 (2.47-3.21)	1001 (2205)
				@ 1200 RPM	@ 1600 RPM	@ 1800 RPM		
MG-6984 SC	7-37008 7-37481 P-71034-B	Ind. 0 00	1.18, 1.54, 2.06, 2.29, 2.52, 2.92 3.25 3.43	902 (1210) 818 (1097) 616 (826)	1203 (1613) 1090 (1462) 821 (1101)	1353 (1814) 1227 (1645) 924 (1239)	2100	1192 (2628)
MG-6984 A	7-37028 P-71093 P-71094	Ind. 0 00	1.48, 1.97, 2.50, 2.79 2.93	923 (1238) 887 (1189)	1230 (1649) 1182 (1585)	1384 (1856) 1330 (1784)	2100	909 (2000)
MG-6984 RV	7-37042	—	1.48, 1.97, 2.50, 2.79 2.93	923 (1238) 887 (1189)	1230 (1649) 1182 (1585)	1384 (1856) 1330 (1784)	2100	909 (2000)
MGX-61000 SC *	1024420	00 Ind.	2.22, 2.54, 2.72, 3.03, 3.39	1119 (1500)	1491 (2000)	1678 (2250)	2100	1780 (3920)
MG-61242 SC	7-37017	Ind.	1.16, 1.52, 2.08, 2.47 2.96	1315 (1763) 1268 (1700)	1754 (2352) 1691 (2268)	1973 (2646) 1902 (2551)	2100	1050 (2310)
MG-61242 A	7-37046	Ind.	1.42, 2.07, 2.44 2.93	1315 (1763) 1263 (1694)	1754 (2352) 1685 (2260)	1973 (2646) 1896 (2543)	2100	1105 (2431)
MG-61242 RV	7-37049	—	1.42, 2.07, 2.44 2.93	1315 (1763) 1263 (1694)	1754 (2352) 1685 (2260)	1973 (2646) 1896 (2543)	2100	1105 (2431)
MGX-61500 SC *	1024500	Ind.	1.84, 1.98, 2.45, 2.97 3.03, 3.41	1560 (2092) 1333 (1788)	2080 (2789) 1778 (2384)	2340 (3138) 2000 (2682)	2100	1920 (4230)
MGX-61500 SC-HL**	1023610	Ind.	1.84, 1.98, 2.18, 2.45, 2.97	1560 (2092)	2080 (2789)	2340 (3138)	2100	2200 (4846)
MGX-61500 SC-HR**	1023611							

Important — See rating definitions, application information, and torsional compatibility notices on pages 19 and 20.
Ratings shown are in SAE Horsepower (HP). Metric Horsepower equals SAE times 1.014.
Weights are approximate and include flywheel housing adapter and flexible input coupling.

* Consult Twin Disc for availability of MGX-61000 SC and MGX-61500 SC, all ratios.
** Consult Twin Disc for availability and technical details to the horizontal offset transmissions MGX-61500 SC-HL and MGX-61500 SC-HR.

CONTINUOUS DUTY RATINGS FOR STANDARD & QUICKSHIFT® MARINE TRANSMISSIONS



Model	Drawing Number	SAE Housing	Ratios	KILOWATTS (HORSEPOWER)			Maximum Speed (rpm)	Dry Weight (kg (lb))
				@ 1800 RPM	@ 2100 RPM	@ 2300 RPM		
MG-340	IT101317501	5, BW	1.45 2.00 2.60	18 (24) 13 (17) 9 (12)	21 (28) 15 (20) 11 (15)	23 (31) 16 (21) 12 (16)	4500	9 (20)
MG-360	IT101318505	5, BW	1.55 2.00 2.45 2.83	23 (31) 21 (28) 17 (23) 14 (19)	26 (35) 24 (32) 20 (27) 16 (22)	29 (39) 26 (35) 21 (28) 17 (23)	5000	14 (31)
MG-5005 A	IT345ATD0001	3, 4, 5	1.54, 2.00 2.47	35 (47) 26 (35)	41 (55) 30 (40)	45 (60) 33 (44)	4500	25 (55)
MG-5012 SC	IT1013079B01	3, 4, BW	1.52 2.09 2.40 2.78	74 (99) 64 (86) 58 (77) 50 (67)	86 (115) 75 (100) 67 (90) 58 (78)	94 (126) 82 (110) 74 (99) 64 (86)	4500	53 (117)
MG-5020 SC	IT1013049B01	3, 4, BW	1.50, 2.04 2.50 2.94	104 (139) 83 (111) 72 (96)	121 (162) 97 (130) 84 (112)	133 (178) 106 (142) 92 (123)	4000	75 (165)
MG-5025 A	IT1013170	3, 4, BW	1.52, 2.09 2.40	59 (79) 52 (70)	69 (93) 61 (82)	75 (101) 67 (90)	4500	36 (79)
MG-5055 A	IT101316101	3, 4, BW	1.53, 2.08 2.60	105 (141) 60 (82)	123 (165) 70 (95)	135 (181) 77 (103)	4000	54 (119)
MG-5010 DC	PX-9400	3, 4, BW	3.00 3.52 4.00	70 (94) 61 (82) 55 (74)	82 (110) 72 (96) 65 (87)	93 (125) 82 (110) 74 (100)	4000	75 (165)
MG-5011 SC	PX-10270	3, 4, BW	1.11, 1.27, 1.50, 2.00 2.44	67 (90) 52 (70)	75 (101) 60 (80)	82 (110) 67 (90)	4400	49 (109)
MG-5011 A	PX-9999	3, 4, BW	1.44, 1.90 2.39	67 (90) 60 (80)	75 (101) 67 (90)	82 (110) 75 (101)	4400	49 (109)
MG-5011 IV	PX-10290	3, 4, BW	1.14, 1.54, 2.06 2.51	67 (90) 52 (70)	75 (101) 60 (80)	82 (110) 67 (90)	4400	77 (170)
MG-5050 SC	PX-12700	1, 2, 3, 4 SPEC. #3	1.00, 1.23, 1.53, 1.71, 2.04, 2.45 3.00	104 (139) 93 (125)	116 (156) 108 (145)	127 (170) 121 (162)	3300	86 (189)
MG-5050 A	PX-12730	1, 2, 3, 4 SPEC. #3	1.12, 1.26, 1.50, 1.80, 2.04, 2.50	104 (139)	116 (156)	127 (170)	3300	80 (176)
MG-5050 RV	PX-8760	—	1.12, 1.26, 1.50, 1.80, 2.04, 2.50	104 (139)	116 (156)	127 (170)	3300	73 (160)
MG-506-1	XA-7022-A XA-7048-A	1, 2, 3 1, 2, 3	1.09, 1.50, 1.97 2.50, 2.96	94 (126) 94 (126)	104 (140) 104 (140)	110 (147) 110 (147)	3000 3000	100 (220) 102 (224)
MG-5061 SC	PX-11650/-A	1, 2, 3 SPEC. #3	1.15, 1.48, 1.77, 2.00, 2.43 3.00	123 (165) 115 (154)	142 (190) 133 (178)	155 (208) 145 (194)	3300	98 (215)
MG-5061 A	PX-11640/-A	1, 2, 3 SPEC. #3	1.13, 1.28, 1.54, 1.75, 2.00 2.47	123 (165) 115 (154)	142 (190) 133 (178)	155 (208) 145 (194)	3300	95 (210)
MG-5061 V	PX-8735	—	1.13, 1.28, 1.54, 1.75, 2.00 2.47	123 (165) 115 (154)	142 (190) 133 (178)	155 (208) 145 (194)	3300	95 (210)
MG-5062 V	PX-11660/-A	1, 2, 3 SPEC. #3	1.19, 1.53, 1.83, 2.07, 2.51	123 (165)	142 (190)	155 (208)	3300	142 (312)
MGX-5065 SC	PX-12410	1, 2, 3 SPEC. #3	1.08, 1.26, 1.47, 1.72, 2.04 2.43	216 (290) 199 (267)	250 (335) 232 (311)	272 (365) 254 (341)	3200	111 (244)
MGX-5065 A	PX-12370	1, 2, 3 SPEC. #3	1.08, 1.26, 1.47, 1.72, 2.04 2.43	216 (290) 199 (267)	250 (335) 232 (311)	272 (365) 254 (341)	3200	111 (244)
MG-5065 SC	PX-11480	1, 2, 3 SPEC. #3	1.08, 1.26, 1.47, 1.72, 2.04 2.43	216 (290) 199 (267)	250 (335) 232 (311)	272 (365) 254 (341)	3200	111 (244)
MG-5065 A	PX-11165	1, 2, 3 SPEC. #3	1.08, 1.26, 1.47, 1.72, 2.04 2.43	216 (290) 199 (267)	250 (335) 232 (311)	272 (365) 254 (341)	3200	111 (244)

Important — See rating definitions, application information, and torsional compatibility notices on pages 19 and 20.
Ratings shown are in SAE Horsepower (HP). Metric Horsepower equals SAE times 1.014.
Weights are approximate and include flywheel housing adapter and flexible input coupling.

CONTINUOUS DUTY RATINGS FOR STANDARD & QUICKSHIFT® MARINE TRANSMISSIONS (Continued)



Model	Drawing Number	SAE Housing	Ratios	KILOWATTS (HORSEPOWER)			Maximum Speed (rpm)	Dry Weight (kg (lb))
				@ 1800 RPM	@ 2100 RPM	@ 2300 RPM		
MGX-5075 SC	PX-12620	1, 2, 3 SPEC. #3	1.06, 1.22, 1.33, 1.53, 1.77, 2.05 2.53, 2.88	186 (249)	209 (280)	224 (300)	3500	122 (268)
MGX-5075 A	PX-12610	1, 2, 3 SPEC. #3	1.06, 1.22, 1.33, 1.53, 1.77, 2.05 2.53, 2.88	186 (249)	209 (280)	224 (300)	3500	122 (268)
MGX-5075 IV	PX-12630	1, 2, 3 SPEC. #3	1.03, 1.30, 1.49, 1.72, 1.99, 2.46	186 (249)	209 (280)	224 (300)	3500	150 (330)
MG-5075 SC	PX-10680/A	1, 2, 3 SPEC. #3	1.06, 1.22, 1.33, 1.53, 1.77, 2.05 2.53, 2.88	186 (249)	209 (280)	224 (300)	3500	122 (268)
MG-5075 A	PX-10700/A	1, 2, 3 SPEC. #3	1.06, 1.22, 1.33, 1.53, 1.77, 2.05 2.53, 2.88	186 (249)	209 (280)	224 (300)	3500	122 (268)
MG-5075 IV	PX-11530	1, 2, 3 SPEC. #3	1.03, 1.30, 1.49, 1.72, 1.99, 2.46	186 (249)	209 (280)	224 (300)	3500	150 (330)
MG-509	X-9816-F	1, 2	1.45, 2.00 2.48 2.95 3.39	175 (235) 170 (228) 170 (228) 128 (170)	204 (273) 194 (260) 186 (250) 148 (198)	224 (300)* 213 (285)* 205 (275)* 160 (215)*	3000*	259 (572)
	X-9835	1, 2	3.83, 4.50 4.95	175 (235) 134 (180)	204 (273) 157 (210)	224 (300)* 172 (230)*	3000*	323 (712)
MG-5085 SC	PX-9260-B/-C	1, 2, 3 SPEC. #3	1.05, 1.22, 1.42, 1.76, 1.96 2.33	227 (304) 205 (275)	254 (340) 231 (310)	265 (355) 243 (326)	3200	120 (265)
MG-5085 A	PX-9360-B/-C	1, 2, 3 SPEC. #3	1.05, 1.22, 1.47, 1.72, 2.04 2.43	227 (304) 205 (275)	254 (340) 231 (310)	265 (355) 243 (326)	3200	123 (270)
MG-5082 SC	PX-11250-A	1, 2	1.06, 1.33, 1.53, 1.77, 2.05, 2.53 2.88	262 (351)	292 (392)	310 (416)	3200	135 (298)
MG-5082 A	PX-11040-B	1, 2	1.06, 1.33, 1.53, 1.77, 2.05, 2.53 2.88	262 (351)	292 (392)	310 (416)	3200	135 (298)
MGX-5086 SC	PX-12600	1, 2	1.06, 1.33, 1.53, 1.77, 2.05, 2.53 2.88	262 (351)	292 (392)	310 (416)	3200	135 (298)
MGX-5086 A	PX-12290	1, 2	1.06, 1.33, 1.53, 1.77, 2.05, 2.53 2.88	262 (351)	292 (392)	310 (416)	3200	135 (298)
MG-5091 SC	PX-10016	1, 2	1.17, 1.45, 1.71, 2.04, 2.45, 2.95 3.33	242 (325) 205 (275)	280 (375) 239 (320)	306 (410) 261 (350)	3000	220 (485)
MG-5091 DC	1002155	1, 2	3.82, 4.50 5.05	242 (325) 205 (275)	280 (375) 239 (320)	306 (410) 261 (350)	3000	297 (655)
MG-5090 A	PX-10015	1, 2	1.45, 1.73, 1.96, 2.43	239 (320)	276 (370)	287 (385)	3000	216 (475)
MGX-5095 SC	PX-12480	1, 2	1.15, 1.27, 1.47, 1.71, 2.00, 2.46 2.95	298 (400)	335 (449)	360 (483)	3000	190 (419)
MGX-5095 A	PX-12360	1, 2	1.28, 1.52, 1.81, 2.04 2.48	298 (400)	335 (449)	360 (483)	3000	185 (407)
MGX-5095 RV	PX-12550	—	1.28, 1.52, 1.81, 2.04 2.48	298 (400)	335 (449)	360 (483)	3000	178 (392)
MG-5095 SC	PX-11535	1, 2	1.15, 1.27, 1.47, 1.71, 2.00, 2.46 2.95	298 (400)	335 (449)	360 (483)	3000	190 (419)
MG-5095 A	PX-11495	1, 2	1.28, 1.52, 1.81, 2.04 2.48	298 (400)	335 (449)	360 (483)	3000	185 (407)
MG-5095 RV	PX-11600	—	1.28, 1.52, 1.81, 2.04 2.48	298 (400)	335 (449)	360 (483)	3000	178 (392)

Important — See rating definitions, application information, and torsional compatibility notices on pages 19 and 20.
 Ratings shown are in SAE Horsepower (HP). Metric Horsepower equals SAE times 1.014.
 Weights are approximate and include flywheel housing adapter and flexible input coupling.

* A6911 driving ring has 2150 rpm maximum speed.

CONTINUOUS DUTY RATINGS FOR STANDARD & QUICKSHIFT® MARINE TRANSMISSIONS (Continued)



Model	Drawing Number	SAE Housing	Ratios	KILOWATTS (HORSEPOWER)			Maximum Speed (rpm)	Dry Weight (kg (lb))
				@ 1800 RPM	@ 2100 RPM	@ 2300 RPM		
MGX-5114 SC	PX-12490	1	0.93, 1.02, 1.12, 1.50, 1.74 2.04, 2.54 3.00	358 (480) 358 (480) 328 (440)	410 (550) 410 (550) 373 (500)	444 (595) 444 (595) 403 (540)	2800 at .93:1 3000 for others	203 (447)
MGX-5114 SC-HD	PX-12860	1	1.50, 1.74, 2.04, 2.54 3.00	358 (480) 328 (440)	410 (550) 373 (500)	444 (595) 403 (540)	3000	270 (595)
MGX-5114 DC	PX-12170	1	3.28, 3.43, 4.17, 4.59, 4.86	347 (465)	403 (540)	421 (565)	3000	360 (793)
MGX-5114 A	1024390	1, 2	1.03, 1.20, 1.48, 1.75, 1.92, 2.04 2.50	347 (465) 321 (430)	387 (519) 366 (491)	418 (561) 396 (531)	3000	206 (455)
MGX-5114 RV	PX-11850	—	1.03, 1.20, 1.48, 1.75, 1.92, 2.04 2.50	347 (465) 321 (430)	387 (519) 366 (491)	418 (561) 396 (531)	3000	198 (435)
MGX-5114 IV	PX-12510	1, 2	1.05, 1.23, 1.52, 1.80, 1.97 2.57	347 (465) 321 (430)	387 (519) 366 (491)	418 (561) 396 (531)	3000	270 (595)
MG-5114 SC	PX-9785-B	1	0.93, 1.02, 1.12, 1.50, 1.74, 2.04, 2.54 3.00	358 (480) 328 (440)	410 (550) 373 (500)	444 (595) 403 (540)	2800 at .93:1 3000 for others	203 (447)
MG-5114 SC-HD	PX-11962	1 Ind.	1.50, 1.74, 2.04, 2.54 3.00	358 (480) 328 (440)	410 (550) 373 (500)	444 (595) 403 (540)	3000	270 (595)
MG-5114 DC	PX-10250-A PX-12195(FS)	1 Ind.	3.28, 3.43, 4.17, 4.59, 4.86	347 (465)	403 (540)	421 (565)	3000	368 (810)
MG-5114 A	PX-11915	1, 2	1.03, 1.20, 1.48, 1.75, 1.92, 2.04 2.50	347 (465) 321 (430)	387 (519) 366 (491)	418 (561) 396 (531)	3000	206 (455)
MG-5114 RV	PX-9830-A	—	1.03, 1.20, 1.48, 1.75, 1.92, 2.04 2.50	347 (465) 321 (430)	387 (519) 366 (491)	418 (561) 396 (531)	3000	198 (435)
MG-5114 IV	PX-11920	1, 2	1.05, 1.23, 1.52, 1.80, 1.97 2.57	347 (465) 321 (430)	387 (519) 366 (491)	418 (561) 396 (531)	3000	270 (595)
				@ 1600 RPM	@ 1800 RPM	@ 2100 RPM		
MG-514C SC	X-9784-C	1, 0 (14" only)	1.51, 2.00, 2.50, 3.00, 3.50	254 (340)	283 (380)	313 (420)	2500	524 (1155)
MG-514C DC	X-9786-C	1, 0 (14" only)	4.13, 4.50, 5.16 6.00	254 (340) 242 (325)	283 (380) 272 (365)	313 (420) 302 (405)	2500	658 (1450)
MGX-5135 SC	PX-12450	1, 0	1.10, 1.28, 1.48, 1.73, 2.04, 2.57 2.90	410 (550) 376 (504)	445 (597) 408 (547)	497 (666) 456 (611)	2800	284 (625)
MGX-5135 A	PX-12380	1, 0	1.16, 1.25, 1.53, 1.79, 2.00 2.52	410 (550)	445 (597)	497 (666)	2800	280 (617)
MGX-5135 RV	PX-12520	—	1.16, 1.25, 1.53, 1.79, 2.00 2.52	410 (550)	445 (597)	497 (666)	2800	258 (568)
MG-5135 SC	PX-11590	1, 0	1.10, 1.28, 1.48, 1.73, 2.04, 2.57 2.90	410 (550) 376 (504)	445 (597) 408 (547)	497 (666) 456 (611)	2800	284 (625)
MG-5135 A	PX-11380	1, 0	1.16, 1.25, 1.53, 1.79, 2.00 2.52	410 (550)	445 (597)	497 (666)	2800	280 (617)
MG-5135 RV	PX-11945	—	1.16, 1.25, 1.53, 1.79, 2.00 2.52	410 (550)	445 (597)	497 (666)	2800	258 (568)
MGX-5145 SC	PX-12460	1, 0	1.03, 1.20, 1.33, 1.48, 1.75, 1.96 2.50	510 (684) 438 (587)	552 (740) 485 (650)	596 (799) 555 (744)	2500	325 (716)
MGX-5145 A	PX-12420	1, 0	1.26, 1.48, 1.75, 1.96 2.50	510 (684) 438 (587)	552 (740) 485 (650)	596 (799) 555 (744)	2500	333 (734)
MGX-5145 RV	PX-12530	—	1.26, 1.48, 1.75, 1.96 2.50	510 (684) 438 (587)	552 (740) 485 (650)	596 (799) 555 (744)	2500	295 (650)
MG-5145 SC	PX-10885	1, 0	1.03, 1.20, 1.33, 1.48, 1.75, 1.96 2.50	510 (684) 438 (587)	552 (740) 485 (650)	596 (799) 555 (744)	2500	325 (716)
MG-5145 A	PX-10830	1, 0	1.26, 1.48, 1.75, 1.96 2.50	510 (684) 438 (587)	552 (740) 485 (650)	596 (799) 555 (744)	2500	333 (734)
MG-5145 RV	PX-10880	—	1.26, 1.48, 1.75, 1.96 2.50	510 (684) 438 (587)	552 (740) 485 (650)	596 (799) 555 (744)	2500	295 (650)

Important — See rating definitions, application information, and torsional compatibility notices on pages 19 and 20.
 Ratings shown are in SAE Horsepower (HP). Metric Horsepower equals SAE times 1.014.
 Weights are approximate and include flywheel housing adapter and flexible input coupling.

CONTINUOUS DUTY RATINGS FOR STANDARD & QUICKSHIFT® MARINE TRANSMISSIONS (Continued)



Model	Drawing Number	SAE Housing	Ratios	KILOWATTS (HORSEPOWER)			Maximum Speed (rpm)	Dry Weight (kg (lb))
				@ 1600 RPM	@ 1800 RPM	@ 2100 RPM		
MGX-5147 SC	PX-12470-A	1, 0	1.20, 1.33, 1.48, 1.57, 1.75, 1.96 2.50	565 (758) 481 (645)	612 (821) 537 (720)	660 (885) 615 (825)	2500	325 (716)
MGX-5147 A	PX-12430-A	1, 0	1.26, 1.48, 1.75, 1.96 2.50	565 (758) 481 (645)	612 (821) 537 (720)	660 (885) 615 (825)	2500	333 (734)
MGX-5147 RV	PX-12540-A	—	1.03, 1.20, 1.33, 1.48, 1.75, 1.96 2.50	565 (758) 481 (645)	612 (821) 537 (720)	660 (885) 615 (825)	2500	295 (650)
MGX-516 DC	1023380	1, 0 (14" only)	3.07, 3.50, 4.04, 4.52, 5.05 6.00	397 (532) 365 (489)	447 (600) 406 (544)	465 (624) 425 (570)	2500	717 (1580)
MGX-5170 DC	1023382	1, 0	3.12, 3.54, 4.06, 4.50, 5.03, 5.95 6.53, 6.95	448 (601) 408 (547)	507 (680) 459 (615)	541 (725) 478 (641)	2500	850 (1872)
MG-520-1HP	XA-7255-B	0	4.49, 5.00, 6.11 7.00 7.42	567 (760) 567 (760) 537 (720)	639 (857) 638 (856) 597 (801)	745 (999) 730 (979) 684 (917)	2500	1559 (3436)
MG-5202 SC	1016103-C	1, 0 Ind.	1.17, 1.33, 1.53, 1.76, 2.03, 2.48, 2.92 3.48	540 (724)	600 (805)	678 (909)	2500	587 (1292)
MG-5203 SC	1016249-A	1, 0 Ind.	1.17, 1.33, 1.53, 1.76, 2.03, 2.48, 2.92 3.48	540 (724)	600 (805)	678 (909)	2500	409 (900)
MG-5204 SC	1016250-B	1, 0 Ind.	1.17, 1.33, 1.53, 1.76, 2.03, 2.48, 2.92 3.48	633 (849) 540 (724)	716 (960) 600 (805)	797 (1069) 678 (909)	2750 (2500 at 1.17:1)	409 (900)
MGX-5222 DC	1022822-A	1, 0 Ind.	4.03, 4.59, 5.04, 6.10, 6.55, 6.96	540 (724)	600 (805)	678 (909)	2500	1046 (2304)
MGX-5225 DC	1022825-A	1, 0 Ind.	4.03, 4.59, 5.04, 5.57, 6.10	633 (849)	716 (960)	735 (986)	2500	1046 (2304)
MGX-5321 DC	1022203-B	0, 00 Ind.	3.35, 4.06, 4.42, 4.96, 5.46 5.96 6.39	882 (1183) 861 (1155) 737 (988)	982 (1317) 955 (1281) 812 (1089)	1000 (1341) 968 (1298) 905 (1214)	2400	1754 (3864)
				@ 1200 RPM	@ 1600 RPM	@ 1800 RPM		
MG-540 (with rubber block drive)	X-9882-C	0 00, Ind.	1.93, 2.58, 2.90 3.26 3.91 4.60 5.17 6.18 7.00 7.47	708 (949) 638 (856) 559 (750) 682 (915) 638 (856) 638 (856) 496 (665) 466 (625)	865 (1160) 809 (1085) 721 (967) 844 (1132) 809 (1085) 809 (1085) 663 (889) 647 (868)	943 (1265)* 895 (1200)* 802 (1075)* 925 (1240)* 895 (1200)* 895 (1200)* 746 (1000)* 738 (990)*	1900* 2100* 2400* 1900* 2100* 2400* 2400* 2400*	2019 (4450) 2105 (4640)
MG-540 (with flexible coupling)	X-9882-C	0 00, Ind.	1.93, 2.58, 2.90 3.26 3.91 4.60 5.17 6.18 7.00 7.47	787 (1055) 776 (1041) 648 (869) 787 (1055) 774 (1038) 644 (864) 571 (766) 535 (717)	1049 (1407) 1034 (1387) 864 (1159) 1049 (1407) 1032 (1384) 859 (1152) 762 (1022) 715 (959)	1180 (1582) 1163 (1560) 972 (1303) 1180 (1582) 1161 (1557) 966 (1295) 895 (1200) 804 (1078)	1900 2100 2400 1900 2100 2400 2400 2400	2019 (4450) 2105 (4640)
MG-5506	00D005604	0, 00 Ind.	4.03, 4.55, 4.96, 5.44 6.00	937 (1257) 848 (1137)	1249 (1675) 1130 (1515)	1406 (1885) 1279 (1715)	2000	2200 (4846)
MGX-5600	1022780	0, 00 Ind.	2.53, 2.98, 3.51, 4.03, 4.63, 5.04 5.76 6.04	1230 (1649) 1200 (1609) 985 (1321)	1575 (2112) 1566 (2100) 1271 (1704)	1760 (2360) 1737 (2329) 1410 (1891)	2100	3132 (6890)
MGX-5600DR	1022781	Ind.	4.20, 6.02 6.56 7.01 7.22	1151 (1543) 1038 (1392) 964 (1293) 845 (1133)	1564 (2097) 1458 (1955) 1352 (1813) 1088 (1459)	1760 (2360) 1641 (2201) 1566 (2100) 1207 (1619)	2100	3475 (7654)

Important — See rating definitions, application information, and torsional compatibility notices on pages 19 and 20.
Ratings shown are in SAE Horsepower (HP). Metric Horsepower equals SAE times 1.014.
Weights are approximate and include flywheel housing adapter and flexible input coupling.

* The max. input speed is 1650 rpm if MG-540 - SAE #00 is used with 21" rubber block drive.

CONTINUOUS DUTY RATINGS FOR STANDARD & QUICKSHIFT® MARINE TRANSMISSIONS (Continued)



Model	Drawing Number	SAE Housing	Ratios	KILOWATTS (HORSEPOWER)			Maximum Speed (rpm)	Dry Weight (kg (lb))
				@ 1200 RPM	@ 1600 RPM	@ 1800 RPM		
MGN-1814 V	PPD007097	Ind.	2.53, 3.00, 3.29 3.62, 4.00	1548 (2076)	2064 (2768)	2322 (3114)	1800	3000 (6608)
MGN-1816 V	PPD007098	Ind.	4.43, 4.85 5.33, 5.61	1548 (2076)	2064 (2768)	2322 (3114)	1800	3800 (8370)
MGN-1817 V	PPD007099	Ind.	6.00, 6.56, 6.88 7.22, 7.59	1548 (2076)	2064 (2768)	2322 (3114)	1800	4500 (9912)
MGN-1819 V	PLN005679	Ind.	8.88	1500 (2012)	2000 (2682)	2250 (3017)	1800	TBA (TBA)
				@ 1600 RPM	@ 1800 RPM	@ 2100 RPM		
MG-6449 A	7-37423	1, 0 Ind.	1.51, 1.73 2.07 2.44 2.95	640 (858) 529 (709) 462 (620) 413 (554)	695 (932) 574 (770) 502 (673) 448 (601)	778 (1043) 642 (861) 562 (754) 501 (672)	2500	344 (757)
MG-6449 RV	7-37431-A	—	1.51, 1.73 2.07 2.44 2.95	640 (858) 529 (709) 462 (620) 413 (554)	695 (932) 574 (770) 502 (673) 448 (601)	778 (1043) 642 (861) 562 (754) 501 (672)	2500	325 (716)
MGX-6598 DC	7-40379	1, 0 Ind.	2.46, 3.03 3.48 3.93 4.43	710 (952) 670 (898) 611 (819) 570 (764)	771 (1034) 729 (978) 664 (890) 619 (830)	858 (1151) 811 (1088) 739 (991) 690 (925)	2500	580 (1278)
MGX-6599 SC	7-40384	1, 0 Ind.	1.07, 1.30, 1.50, 1.66, 1.74 1.97, 2.04, 2.19, 2.45 2.82	685 (919) 670 (898) 575 (771)	744 (998) 728 (976) 624 (837)	828 (1110) 806 (1081) 696 (933)	2500	492 (1084)
MGX-6599 A	7-40263	1, 0 Ind.	1.34, 1.51, 1.74, 2.03, 2.24 2.48 2.80	706 (947) 668 (896) 644 (864)	767 (1029) 728 (976) 699 (937)	851 (1141) 804 (1078) 779 (1045)	2500	488 (1075)
MGX-6599 RV	7-40336	—	1.34, 1.51, 1.74, 2.03, 2.24 2.48 2.80	706 (947) 668 (896) 644 (864)	767 (1029) 728 (976) 699 (937)	851 (1141) 804 (1078) 779 (1045)	2500	468 (1031)
MG-6600 DC	7-36712-A	0 Ind.	3.30, 4.11 4.68, 4.72 5.22 6.05	637 (854) 623 (835) 534 (716) 473 (634)	716 (960) 701 (940) 600 (805) 532 (713)	835 (1120) 818 (1097) 699 (937) 621 (833)	2500	794 (1747)
MGX-6620 SC	7-40337	0 Ind.	1.15, 1.33, 1.53, 1.73 2.03 2.32 2.44 2.72	827 (1109) 810 (1086) 805 (1080) 780 (1046) 723 (970)	898 (1204) 879 (1179) 874 (1172) 847 (1136) 785 (1053)	934 (1252) 934 (1252) 934 (1252) 934 (1252) 875 (1173)	2500	575 (1267)
MGX-6620 A	7-40264	0 Ind.	1.55, 1.72, 2.09 2.28, 2.42 2.73	875 (1173) 767 (1029) 719 (964)	950 (1274) 833 (1117) 780 (1046)	1059 (1420) 928 (1244) 869 (1165)	2500	580 (1278)
MGX-6620 RV	7-40316	—	1.55, 1.72, 2.09 2.28, 2.42 2.73	875 (1173) 767 (1029) 719 (964)	950 (1274) 833 (1117) 780 (1046)	1059 (1420) 928 (1244) 869 (1165)	2500	510 (1123)
MGX-6650 SC	1002046	0, 00 Ind.	1.51, 1.88, 2.03, 2.37 2.47, 2.93, 3.21	911 (1222)	1025 (1375)	1098 (1472)	2300 (1.51–2.37) 2500 (2.47–3.21)	1001 (2205)
MGX-6690 SC	1020674	0, 00 Ind.	1.51, 1.88, 2.03, 2.37, 2.47 2.93 3.21	1017 (1364) 977 (1310) 943 (1265)	1129 (1514) 1069 (1434) 1028 (1379)	1195 (1602) 1130 (1515) 1098 (1472)	2300 (1.51–2.37) 2500 (2.47–3.21)	1001 (2205)
MGX-6848 SC	1020675	0, 00 Ind.	1.51, 1.88, 2.03, 2.47, 2.58, 2.93 3.21	1111 (1490) 1074 (1440)	1250 (1676) 1194 (1601)	1420 (1904) 1350 (1810)	2300 (1.51–2.03) 2500 (2.47–3.21)	1001 (2205)

Important — See rating definitions, application information, and torsional compatibility notices on pages 19 and 20.
 Ratings shown are in SAE Horsepower (HP). Metric Horsepower equals SAE times 1.014.
 Weights are approximate and include flywheel housing adapter and flexible input coupling.

CONTINUOUS DUTY RATINGS FOR STANDARD & QUICKSHIFT® MARINE TRANSMISSIONS (Continued)



Model	Drawing Number	SAE Housing	Ratios	KILOWATTS (HORSEPOWER)			Maximum Speed (rpm)	Dry Weight (kg (lb))
				@ 1200 RPM	@ 1600 RPM	@ 1800 RPM		
MG-6984 SC	7-37008	Ind.	1.18, 1.54, 2.06, 2.29, 2.52, 2.92	884 (1185)	1178 (1580)	1326 (1778)	2100	1192 (2628)
	7-37481	0	3.25	800 (1073)	1066 (1430)	1200 (1609)		
	P-71034-B	00	3.43	602 (807)	802 (1075)	903 (1211)		
MG-6984 A	7-37028	Ind.	1.48, 1.97, 2.50, 2.79	905 (1214)	1206 (1617)	1356 (1818)	2100	909 (2000)
	P-71093	0	2.93	867 (1163)	1157 (1552)	1301 (1745)		
	P-71094	00						
MG-61242 SC	7-37017	Ind.	1.16, 1.52	1250 (1676)	1667 (2235)	1875 (2514)	2100	1050 (2310)
			2.08, 2.47, 2.96	1173 (1573)	1512 (2028)	1760 (2360)		
MG-61242 A	7-37046	Ind.	1.42, 2.07	1239 (1661)	1651 (2214)	1858 (2492)	2100	1105 (2431)
			2.44	1189 (1594)	1585 (2125)	1782 (2390)		
			2.93	1173 (1573)	1565 (2099)	1760 (2360)		

Important — See rating definitions, application information, and torsional compatibility notices on pages 19 and 20.
 Ratings shown are in SAE Horsepower (HP). Metric Horsepower equals SAE times 1.014.
 Weights are approximate and include flywheel housing adapter and flexible input coupling.

DIMENSIONS AND WEIGHTS FOR TWIN DISC MARINE TRANSMISSIONS

Ⓐ Vertical Offset

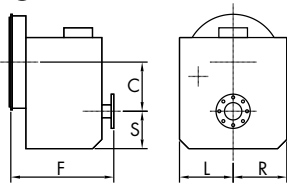

Ⓑ Vertical Offset Downangle

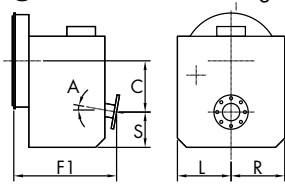

Ⓒ Remote V-Drive

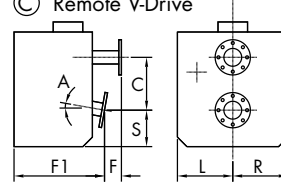

Ⓓ Integral V-Drive

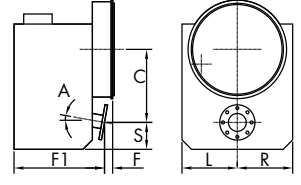

Model	Assembly	Configuration	C (offset) in (mm)	S (sump) in (mm)	F (length) in (mm)	F1 (length) in (mm)	L (mounting pad) in (mm)	R (mounting pad) in (mm)	A degree	Weight lb (kg)
MG-340	IT40TD0002	A	2.66 (68)	2.46 (63)	7.17 (182)	—	—	2.95 (75)	—	20 (9)
MG-360	IT60TD0002	A	3.10 (79)	3.56 (83)	9.65 (245)	—	—	—	—	31 (14)
MG-5005 A	IT345ATD0001	B	4.37 (111)	3.19 (81)	8.82 (224)	—	—	—	8	55 (25)
MG-5012 SC	IT93TD0001	A	4.35 (110)	4.92 (125)	10.14 (258)	—	6.61 (168)	6.61 (168)	—	117 (53)
MG-5020 SC	IT170TD0001	A	5.18 (132)	5.17 (131)	10.53 (268)	—	7.60 (193)	7.60 (193)	—	165 (75)
MG-5025 A	IT485ATD0001	B	4.96 (126)	3.43 (87)	10.63 (270)	—	6.50 (165)	6.50 (165)	8	79 (36)
MG-5055 A	IT880ATD0002	B	6.10 (155)	4.25 (108)	10.51 (267)	—	7.60 (193)	7.60 (193)	10	119 (54)
MG-5010 DC	PX-9400	A	6.56 (167)	6.39 (162)	9.80 (249)	—	7.25 (184)	6.95 (177)	—	165 (75)
MG-5011 SC	PX-10270	A	4.10 (104)	3.50 (89)	8.59 (218)	—	6.75 (171)	5.00 (127)	—	109 (49)
MG-5011 A	PX-9999	B	4.65 (118)	3.66 (93)	7.62 (194)	—	6.75 (171)	5.00 (127)	10	104 (47)
MG-5011 IV	PX-10290	D	10.09 (256)	6.75 (171)	2.71 (69)	9.61 (244)	6.75 (171)	5.00 (127)	15	170 (77)
MG-5050 SC	PX-12700	A	5.28 (134)	4.69 (119)	12.78 (325)	—	8.13 (207)	5.85 (149)	—	189 (86)
MG-5050 A	PX-12730	B	5.52 (140)	3.68 (93)	12.10 (307)	—	8.13 (207)	5.85 (149)	10	176 (80)
MG-5050 RV	PX-8760	C	5.52 (140)	3.68 (93)	3.06 (78)	10.13 (257)	8.13 (207)	5.85 (149)	10	160 (73)
MG-506-1	XA-7022-A	A	coax (0)	7.90 (201)	10.03 (255)	—	7.12 (181)	7.12 (181)	—	220 (100)
MG-506-1	XA-7048-A	A	coax (0)	7.90 (201)	10.42 (265)	—	7.12 (181)	7.12 (181)	—	227 (103)
MG-5061 SC	PX-11650/A	A	5.66 (144)	4.84 (123)	13.18 (335)	—	8.40 (213)	6.15 (156)	—	215 (98)
MG-5061 A	PX-11640/A	B	5.75 (146)	4.21 (107)	12.53 (318)	—	8.40 (213)	6.16 (156)	7	210 (95)
MG-5061 V	PX-8735	C	5.75 (146)	4.21 (107)	2.79 (71)	10.53 (267)	8.40 (213)	6.16 (156)	7	190 (86)
MG-5062 V	PX-11660/A	D	13.03 (331)	3.97 (101)	4.00 (102)	12.92 (328)	8.40 (213)	6.15 (156)	15	312 (142)
MGX-5065 SC	PX-12410	A	6.00 (152)	5.22 (133)	13.30 (338)	—	10.00 (254)	6.50 (165)	—	244 (111)
MGX-5065 A	PX-12370	B	6.69 (170)	4.84 (123)	12.97 (329)	—	10.00 (254)	6.50 (165)	7	244 (111)
MG-5065 SC	PX-11480	A	6.00 (152)	5.22 (133)	13.30 (338)	—	10.00 (254)	6.50 (165)	—	244 (111)
MG-5065 A	PX-11165	B	6.69 (170)	4.84 (123)	12.97 (329)	—	10.00 (254)	6.50 (165)	7	244 (111)
MGX-5075 SC	PX-12620	A	0.59 (15)	7.00 (178)	14.11 (358)	—	10.00 (254)	10.00 (254)	—	268 (122)
MGX-5075 A	PX-12610	B	1.91 (48)	7.00 (178)	13.80 (350)	—	10.00 (254)	10.00 (254)	7	268 (122)
MGX-5075 IV	PX-12630	D	14.70 (373)	3.93 (100)	2.81 (71)	13.94 (354)	10.00 (254)	10.00 (254)	15	330 (150)
MG-5075 SC	PX-11876	A	0.59 (15)	7.00 (178)	14.11 (358)	—	10.00 (254)	10.00 (254)	—	268 (122)
MG-5075 SC	PX-10680/A	A	0.59 (15)	7.00 (178)	14.11 (358)	—	10.00 (254)	10.00 (254)	—	268 (122)
MG-5075 A	PX-10700/A	B	1.91 (48)	7.00 (178)	13.80 (350)	—	10.00 (254)	10.00 (254)	7	268 (122)
MG-5075 IV	PX-11530	D	14.70 (373)	3.93 (100)	2.81 (71)	13.94 (354)	10.00 (254)	10.00 (254)	15	330 (150)
MG-5082 SC	PX-11250-A	A	0.59 (15)	7.00 (178)	16.24 (413)	—	10.00 (254)	10.00 (254)	—	298 (135)
MG-5082 A	PX-11040-B	B	2.12 (54)	7.00 (178)	15.97 (405)	—	10.00 (254)	10.00 (254)	7	298 (135)
MG-5085 SC	PX-9260-B/C	A	6.00 (152)	5.25 (133)	14.67 (373)	—	10.00 (254)	6.50 (165)	—	265 (120)
MG-5085 A	PX-9360-B/C	B	6.69 (170)	4.84 (123)	14.69 (373)	—	10.00 (254)	6.50 (165)	7	270 (123)
MGX-5086 SC	PX-12600	A	0.59 (15)	7.00 (178)	16.24 (413)	—	10.00 (254)	10.00 (254)	—	298 (135)
MGX-5086 A	PX-12290	B	2.12 (54)	7.00 (178)	15.97 (405)	—	10.00 (254)	10.00 (254)	7	298 (135)
MG-509	X-9816-F	A	6.82 (173)	5.85 (149)	15.62 (397)	—	10.25 (260)	10.25 (260)	—	572 (259)
MG-509	X-9835	A	9.49 (241)	9.40 (240)	17.38 (441)	—	11.12 (282)	11.12 (282)	—	712 (323)
MG-5091 SC	PX-10016	A	6.82 (173)	6.22 (158)	16.59 (421)	—	10.25 (260)	6.94 (176)	—	485 (220)
MG-5091 DC	1002155	A	9.49 (241)	9.60 (244)	18.09 (459)	—	11.12 (282)	11.12 (282)	—	655 (297)
MG-5090 A	PX-10015	B	7.30 (185)	5.05 (128)	17.07 (434)	—	10.25 (260)	7.00 (178)	7	475 (215)

Dimensions may vary with housing adapter or output flange.

Use certified drawings for installation.
Dry weights are approximate and vary by input and ratio.
Specifications are subject to change without notice.

DIMENSIONS AND WEIGHTS FOR TWIN DISC MARINE TRANSMISSIONS

Ⓐ Vertical Offset

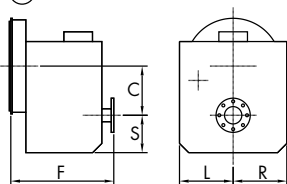

Ⓑ Vertical Offset Downangle

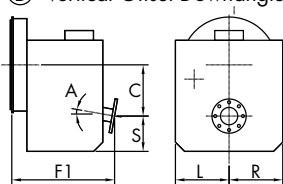

Ⓒ Remote V-Drive

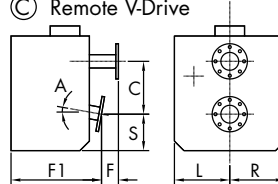

Ⓓ Integral V-Drive

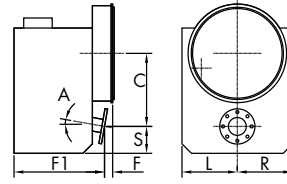

Model	Assembly	Configuration	C (offset) in (mm)	S (sump) in (mm)	F (length) in (mm)	F1 (length) in (mm)	L (mounting pad) in (mm)	R (mounting pad) in (mm)	A degree	Weight lb (kg)
MGX-5095 SC	PX-12480	A	7.48 (190)	6.14 (156)	17.00 (432)	—	10.43 (265)	10.43 (265)	—	419 (190)
MGX-5095 A	PX-12360	B	7.43 (189)	5.54 (141)	17.00 (432)	—	10.43 (265)	10.43 (265)	7	407 (185)
MGX-5095 RV	PX-12550	C	7.43 (189)	5.54 (141)	3.13 (80)	15.24 (387)	10.43 (265)	10.43 (265)	7	392 (178)
MG-5095 SC	PX-11535	A	7.48 (190)	6.14 (156)	17.00 (432)	—	10.43 (265)	10.43 (265)	—	419 (190)
MG-5095 A	PX-11495	B	7.43 (189)	5.54 (141)	17.00 (432)	—	10.43 (265)	10.43 (265)	7	407 (185)
MG-5095 RV	PX-11600	C	7.43 (189)	5.54 (141)	3.13 (80)	15.24 (387)	10.43 (265)	10.43 (265)	7	392 (178)
MGX-5114 SC	PX-12490	A	7.47 (190)	6.33 (161)	19.00 (483)	—	11.00 (279)	7.50 (191)	—	447 (203)
MGX-5114 SC-HD	PX-12860	A	7.47 (190)	6.33 (161)	19.00 (483)	—	11.00 (279)	11.00 (279)	—	595 (270)
MGX-5114 DC	PX-12170	A	10.90 (277)	9.85 (250)	19.03 (483)	—	11.25 (286)	11.25 (286)	—	793 (360)
MGX-5114 A	1024390	B	8.00 (203)	5.30 (135)	18.80 (479)	—	11.00 (279)	8.00 (203)	7	455 (206)
MGX-5114 RV	PX-11850	C	8.00 (203)	5.25 (133)	2.12 (54)	17.69 (449)	11.00 (279)	8.00 (203)	7	435 (198)
MGX-5114 IV	PX-12510	D	16.26 (413)	5.75 (146)	2.43 (62)	19.26 (489)	7.50 (191)	11.50 (292)	14	595 (270)
MG-5114 SC	PX-9785-B	A	7.47 (190)	6.33 (161)	19.00 (483)	—	11.00 (279)	7.50 (191)	—	447 (203)
MG-5114 SC-HD	PX-11962	A	7.47 (190)	6.33 (161)	19.00 (483)	—	11.00 (279)	11.00 (279)	—	595 (270)
MG-5114 DC	PX-10250-A	A	10.90 (277)	9.85 (250)	19.03 (483)	—	11.25 (286)	11.25 (286)	—	800 (364)
MG-5114 A	PX-11915	B	8.00 (203)	5.30 (133)	18.80 (479)	—	11.00 (279)	8.00 (203)	7	455 (206)
MG-5114 RV	PX-9830-A	C	8.00 (203)	5.25 (133)	2.12 (54)	17.69 (449)	11.00 (279)	8.00 (203)	7	435 (198)
MG-5114 IV	PX-11920	D	16.26 (413)	5.75 (146)	2.43 (62)	19.26 (489)	7.50 (191)	11.50 (292)	14	595 (270)
MG-514C SC	X-9784-C	A	9.32 (237)	9.77 (248)	19.51 (496)	—	14.75 (375)	12.75 (324)	—	1155 (524)
MG-514C DC	X-9786-C	A	13.29 (338)	12.77 (324)	22.14 (562)	—	14.00 (356)	14.00 (356)	—	1450 (658)
MGX-5135 SC	PX-12450	A	7.87 (200)	7.48 (190)	21.06 (535)	—	12.01 (305)	12.01 (305)	—	625 (284)
MGX-5135 A	PX-12380	B	9.09 (231)	6.28 (160)	20.48 (520)	—	12.01 (305)	12.01 (305)	10	617 (280)
MGX-5135 RV	PX-12520	C	9.09 (231)	6.28 (160)	4.55 (116)	22.91 (582)	12.01 (305)	12.01 (305)	10	568 (258)
MG-5135 SC	PX-11590	A	7.87 (200)	7.48 (190)	21.06 (535)	—	12.01 (305)	12.01 (305)	—	625 (284)
MG-5135 A	PX-11380	B	9.09 (231)	6.28 (160)	20.48 (520)	—	12.01 (305)	12.01 (305)	10	617 (280)
MG-5135 RV	PX-11945	C	9.09 (231)	6.28 (160)	4.55 (116)	22.91 (582)	12.01 (305)	12.01 (305)	10	568 (258)
MGX-5145 SC	PX-12460	A	8.12 (206)	7.04 (179)	21.05 (535)	—	12.01 (305)	12.01 (305)	—	716 (325)
MGX-5145 A	PX-12420	B	10.40 (264)	6.13 (156)	20.33 (516)	—	12.01 (305)	12.01 (305)	10	734 (333)
MGX-5145 RV	PX-12530	C	10.40 (264)	6.13 (156)	5.77 (147)	18.06 (459)	12.01 (305)	12.01 (305)	10	650 (295)
MG-5145 SC	PX-10885	A	8.12 (206)	7.04 (179)	21.05 (535)	—	12.01 (305)	12.01 (305)	—	716 (325)
MG-5145 A	PX-10830	B	10.40 (264)	6.13 (156)	20.33 (516)	—	12.01 (305)	12.01 (305)	10	734 (333)
MG-5145 RV	PX-10880	C	10.40 (264)	6.13 (156)	5.77 (147)	18.06 (459)	12.01 (305)	12.01 (305)	10	650 (295)
MGX-5147 SC	PX-12470-A	A	8.12 (206)	7.04 (179)	21.05 (535)	—	12.01 (305)	12.01 (305)	—	716 (325)
MGX-5147 A	PX-12430-A	B	10.40 (264)	6.13 (156)	20.33 (516)	—	12.01 (305)	12.01 (305)	10	734 (333)
MGX-5147 RV	PX-12540-A	C	10.40 (264)	6.13 (156)	5.77 (147)	18.06 (459)	12.01 (305)	12.01 (305)	10	650 (295)
MGX-516 DC	1023380	A	13.29 (338)	12.77 (324)	20.59 (523)	—	14.00 (356)	14.00 (356)	—	1580 (717)
MGX-5170 DC	1023382	A	15.15 (385)	14.23 (361)	22.55 (573)	—	15.00 (381)	15.00 (381)	—	1670 (759)

Dimensions may vary with housing adapter or output flange.

Use certified drawings for installation.
Dry weights are approximate and vary by input and ratio.
Specifications are subject to change without notice.

DIMENSIONS AND WEIGHTS FOR TWIN DISC MARINE TRANSMISSIONS

Ⓐ Vertical Offset

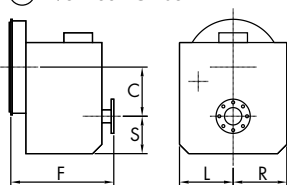

Ⓑ Vertical Offset Downangle

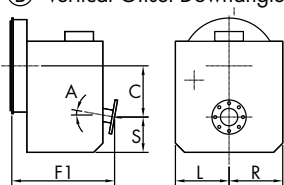

Ⓒ Remote V-Drive

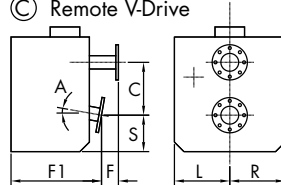

Ⓓ Integral V-Drive

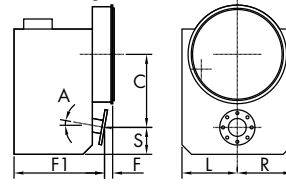

Model	Assembly	Configuration	C (offset) in (mm)	S (sump) in (mm)	F (length) in (mm)	F1 (length) in (mm)	L (mounting pad) in (mm)	R (mounting pad) in (mm)	A degree	Weight lb (kg)
MG-520-1HP	XA-7255-B	A	16.44 (418)	16.55 (420)	30.86 (784)	—	16.00 (406)	16.00 (406)	—	3436 (1560)
MG-5202 SC	1016103-C	A	9.75 (248)	8.75 (222)	23.45 (595)	—	14.75 (375)	10.50 (267)	—	1275 (580)
MG-5203 SC	1016249-A	A	9.75 (248)	8.75 (222)	23.43 (595)	—	14.75 (375)	10.50 (267)	—	900 (409)
MG-5204 SC	1016250-B	A	9.75 (248)	8.75 (222)	23.43 (595)	—	14.75 (375)	10.50 (267)	—	900 (409)
MGX-5222 DC	1022822	A	15.75 (400)	15.13 (384)	25.08 (637)	—	16.00 (406)	16.00 (406)	—	2304 (1046)
MGX-5225 DC	1022825	A	15.75 (400)	15.13 (384)	25.08 (637)	—	16.00 (406)	16.00 (406)	—	2304 (1046)
MGX-5321 DC	1022203-B	A	17.32 (440)	16.77 (426)	29.83 (758)	—	17.32 (440)	17.32 (440)	—	3864 (1754)
MG-540	X-9882-C	A	8.08 (205)	13.45 (342)	36.47 (926)	—	16.00 (406)	16.00 (406)	—	4450 (2019)
MG-5506	000005604	A	19.29 (490)	19.29 (490)	39.17 (995)	—	20.08 (510)	20.08 (510)	—	4846 (2200)
MGX-5600	1022780	A	21.65 (550)	21.26 (540)	41.02 (1042)	—	20.67 (525)	20.67 (525)	—	6890 (3132)
MGX-5600 DR	1022781	A	8.85 (225)	21.26 (540)	50.63 (1286)	—	20.67 (525)	20.67 (525)	—	7000 (3175)
MGN-1814 V	DDP007097	A	16.73 (425)	19.69 (500)	55.12 (1400)	—	27.56 (700)	23.62 (600)	—	6608 (3000)
MGN-1816 V	DDP007098	A	21.26 (540)	22.83 (580)	55.12 (1400)	—	29.53 (750)	29.53 (750)	—	8370 (3800)
MGN-1817 V	DDP007099	A	26.38 (670)	27.56 (700)	55.12 (1400)	—	31.50 (800)	31.50 (800)	—	9912 (4500)
MGN-1819 V	PLN005679	A	30.71 (780)	33.46 (850)	55.12 (1400)	—	37.40 (950)	37.40 (950)	—	TBA (TBA)
MG-6449 A	7-37423	B	10.83 (275)	4.92 (125)	20.83 (529)	—	12.01 (305)	12.01 (305)	10	757 (344)
MG-6449 RV	7-37431-A	C	10.88 (276)	6.44 (164)	6.32 (161)	20.32 (516)	12.01 (305)	12.01 (305)	10	782 (355)
MGX-6598 DC	7-40379	A	12.20 (310)	10.83 (275)	23.72 (603)	—	14.17 (360)	14.17 (360)	—	1278 (580)
MGX-6599 SC	7-40384	A	8.66 (220)	9.29 (236)	23.31 (592)	—	13.39 (340)	13.39 (340)	—	1084 (492)
MGX-6599 A	7-40263	B	11.70 (297)	6.25 (159)	22.60 (574)	—	13.39 (340)	13.39 (340)	10	1075 (488)
MGX-6599 RV	7-40336	C	11.70 (297)	6.25 (159)	6.06 (154)	20.63 (524)	13.39 (340)	13.39 (340)	10	1031 (468)
MG-6600 DC	7-36712-A	A	14.17 (360)	14.96 (380)	30.87 (784)	—	14.76 (375)	14.76 (375)	—	1747 (794)
MGX-6620 SC	7-40337	A	9.25 (235)	9.25 (235)	27.48 (698)	—	13.39 (340)	13.39 (340)	—	1267 (575)
MGX-6620 A	7-40264	B	12.44 (316)	7.25 (184)	25.70 (653)	—	13.39 (340)	13.39 (340)	10	1278 (580)
MGX-6620 RV	7-40316	C	12.44 (316)	7.25 (184)	5.06 (129)	23.74 (603)	13.39 (340)	13.39 (340)	10	1123 (510)
MGX-6650 SC	1002046	A	12.21 (310)	11.81 (300)	30.13 (765)	—	17.32 (440)	17.32 (440)	—	2205 (1001)
MGX-6690 SC	1020674	A	12.21 (310)	11.81 (300)	30.13 (765)	—	17.32 (440)	17.32 (440)	—	2205 (1001)
MGX-6848 SC	1020675	A	12.21 (310)	11.81 (300)	30.13 (765)	—	17.32 (440)	17.32 (440)	—	2205 (1001)
MG-6984 SC	7-37008	A	12.21 (310)	11.30 (287)	27.20 (691)	—	17.52 (445)	17.52 (445)	—	2628 (1192)
MG-6984 A	7-37028	B	15.04 (382)	8.50 (216)	26.93 (684)	—	17.52 (445)	17.52 (445)	10	1991 (905)
MG-6984 RV	7-37042	C	15.04 (382)	8.50 (216)	11.82 (300)	30.86 (784)	17.52 (445)	17.52 (445)	10	2002 (910)
MGX-61000 SC	1024420	A	14.96 (380)	14.17 (360)	39.08 (993)	—	19.29 (490)	19.29 (490)	—	1780 (3920)
MG-61242 SC	7-37017	A	13.39 (340)	12.17 (309)	29.80 (757)	—	19.69 (500)	19.69 (500)	—	2310 (1050)
MG-61242 A	7-37046	B	17.52 (445)	9.49 (241)	30.35 (771)	—	19.69 (500)	19.69 (500)	10	2431 (1105)
MG-61242 RV	7-37049	C	17.52 (445)	9.49 (241)	11.34 (288)	32.56 (827)	19.69 (500)	19.69 (500)	10	2475 (1125)
MGX-61500 SC	1022390	A	18.11 (460)	15.63 (397)	40.63 (1032)	—	18.23 (463)	18.23 (463)	—	1920 (4230)
MGX-5170 DC	1023382	A	15.15 (385)	14.23 (361)	22.55 (573)	—	15.00 (381)	15.00 (381)	—	1670 (759)

Dimensions may vary with housing adapter or output flange.

Use certified drawings for installation.
Dry weights are approximate and vary by input and ratio.
Specifications are subject to change without notice.

TWIN DISC, INCORPORATED

1328 RACINE STREET
RACINE, WISCONSIN 53403 USA
TELEPHONE: +1 (262) 638-4000
TELEFAX: +1 (262) 638-4480



TWIN DISC INTERNATIONAL SA

Chaussée de Namur, 54
B-1400 Nivelles
Belgium
Telephone: +32 (0) 67 887 211
Telefax: +32 (0) 67 887 333
E-mail: tdbelgium@twindisc.com

TWIN DISC SRL

Via S. Cristoforo 131
40017 S. Matteo Della Decima (BO)
Italy
Telephone: +39 051 6819711
Telefax: +39 051 6824234
6825814
E-mail: info.technodrive@twindisc.com

TWIN DISC SRL

Via E.e P. Salani 1
50050 Limite Sull'Arno (FI)
Italy
Phone: +39 0571 979111
Telefax: +39 0571 979143
E-Mail: info.bcs@twindisc.com

TWIN DISC, INC.

Latin America Office
Psj Los Centinelas 125-9C
Las Casuarinas-Surco
Lima 33
Peru
Telephone: +1 (305) 434-7801
Telephone: +51 1 652 4433
Telefax: +51 1 652 4434
Cell: +51 1 9 9167 4400
E-mail: eberhardt.erwin@twindisc.com

TWIN DISC (PACIFIC) PTY LTD

Queensland Head Office
40 Telford Street
Virginia QLD 4014
Australia
Telephone: +61 (7) 3265-1200
Cell: +61 (7) 3865-1371
E-mail: twindisc.brisbane@twindisc.com.au

TWIN DISC (FAR EAST) LTD

10, Fifth Lok Yang Road
Jurong 629 761
Singapore
Telephone: +65 62670800
Telefax: +65 62642080
E-mail: emily.ang@twindisc.com

TWIN DISC, INC.

Shanghai Representative Office
2108, Shartex Plaza
88 Zunyi Road (S)
Shanghai, 200336
China
Telephone: +86 (21) 6427 3212
+86 (21) 6209 7626
Telefax: +86 (21) 6209 7629
E-mail: tdchina@online.sh.cn

Guangzhou Representative Office
Room 908, Building C, 11 Yiyiing Street,
Xi Gang Road (M), Hai Zhu Dist,
Guangzhou
China 510315
Telephone: +86 (20) 3435 0927
Telefax: +86 (20) 3439 1441
E-mail: jason.yang@twindisc.com.cn

ROLLA SP PROPELLERS SA

Via Roncaglia 6
P.O. Box 109
Novazzano, 6883
Switzerland
Phone: + 41 (0) 91 695 2000
Telefax: + 41 (0) 91 695 2001
E-mail: info@rolla-propellers.ch

TWIN DISC JAPAN

Twin Disc Nico Co. Ltd.
405-3, Yoshinocho 1-chome, Kita-ku
Saitama-shi, Saitama-ken, 331-0811
Japan
Phone: +81 (48) 652-8069
Telefax: +81 (48) 665-6695
E-Mail: info@tdnico.com

**TWIN DISC, INCORPORATED
RACINE, WISCONSIN, U.S.A.**

UNITED STATES OF AMERICA • AUSTRALIA • BELGIUM
FRANCE • ITALY • SINGAPORE • SWITZERLAND

Bulletin 319-A-MPG 5M-1/11 Printed in the USA

WWW.TWINDISC.COM